

Asada

RECIPROCATING SAW

PIPE SAW 200SP

INSTRUCTION MANUAL

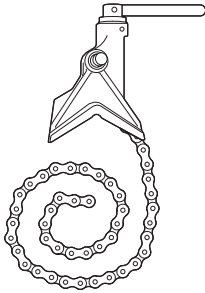

With Chain Vise

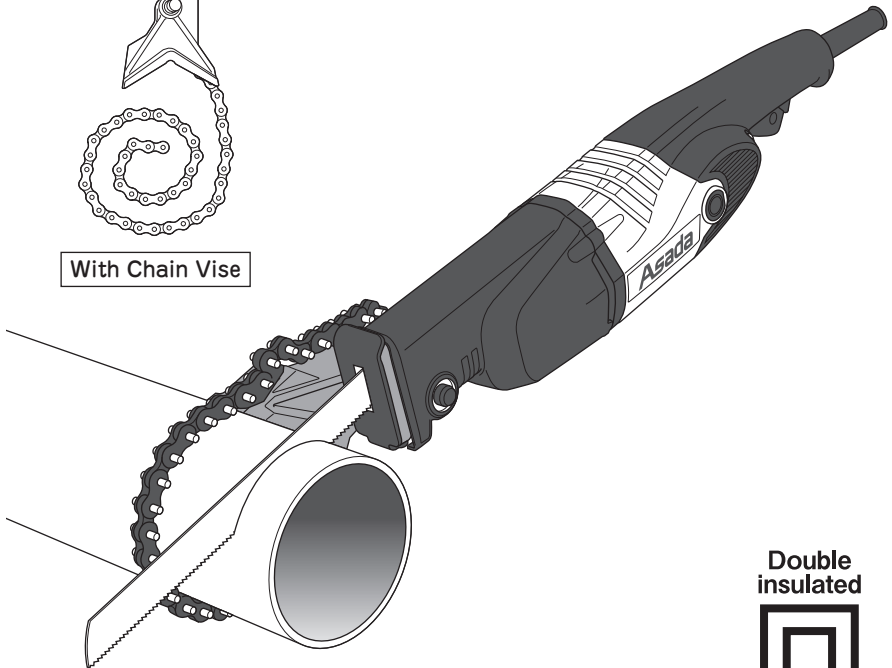

Double
insulated



[Please read this manual before operating.]

PIPE SAW 200SP

SAFETY PRECAUTIONS

Thank you for choosing the PIPE SAW 200SP.

- This manual should be handed over to the end user.
- The content of this manual must be thoroughly read and understood securely before operating.
- Please save this manual for immediate reference when required.
- Use the machine for the intended application only.

This machine is designed to cut existing pipes and angles of steel, stainless steel, PVC, etc.

- Check the following as soon the machine is delivered:
 - Is the specification same as the ordered product?
 - Is there any damage or deformation caused during delivery transit?
 - Is there any shortage of accessories?

If any dissatisfaction is found, please contact with the store you have purchased or our sales department.

(The contents of instruction manual will be changed without notice for quality improvement.)

DEFINITIONS OF THE DANGER, WARNING, CAUTION SYMBOLS

In this manual and on the machine, the safety instruction levels are classified into as following three levels.



Denotes that incorrect handling would cause immediate death or injury to the user and others.



Denotes that incorrect handling can cause death or injury to the user and others.



Denotes that incorrect handling can cause user injury or physical damage.

CONTENTS

SAFETY INSTRUCTIONS	2	HOW TO OPERATE THE MACHINE	10
OPERATING INSTRUCTIONS	5	How to Set the Saw Blade	10
PARTS IDENTIFICATION	7	How to Set the Saber Saw Blade	12
Name of Parts	7	Cutting with Chain Vise	13
Specifications	7	Cutting without Chain Vise	15
Standard Accessories	8	Adjustment of Saw Blade Speed	16
Optional Accessories	8	The Over-Load Protector	16
PREPARATIONS BEFORE		DAILY INSPECTION AND CARE	17
STARTING OPERATION	9	TROUBLESHOOTING	18
Confirmation of the Earth Leakage Circuit Breaker	9		
Extension Cord	9		
Maintaining and Checking the Working Environment	9		

PIPE SAW 200SP

SAFETY INSTRUCTIONS

- To prevent accidents such as fire, electrical shock and injury, always follow the "SAFETY INSTRUCTIONS" described below.
- Before using the machine, read all "SAFETY INSTRUCTIONS" to use it correctly according to the instructions.
- After reading the instructions, save this manual so that you can read it when necessary.

WARNING

◆ Operate the machine on the correct voltage.

Always use the machine at the rated voltage indicated in the machine plate or instruction manual.

Otherwise, the machine will overheat, emit smoke or catch fire.

◆ Make sure that the switch is OFF before plugging the machine in.

Before plugging the machine in, always make sure that the switch is OFF to avoid accident or injury. If the switch is ON, the machine will start suddenly, leading to unexpected accident.

◆ Guard against electrical shock.

Do not touch the plug with wet hands.

Do not expose the machine to rain and water.

Always ground the machine to avoid electrical shock.(Except the double-insulated machine)

◆ Avoid dangerous environment.

Do not expose the machine to rain or water and do not use it in damp or wet locations. Humidity will deteriorate motor insulation or lead to electrical shock.

Do not use the machine in the presence of flammable liquids or gases such as gasoline and thinner. Otherwise, ignition or explosion may take place.

◆ Use safety goggles.

Wear safety goggles while operating the machine. Also use a face or dust mask if operation creates dust. Sawdust and dirt may enter your eyes and nose.

◆ Secure work piece.

Use clamps or a vise as described in the manual to hold a workpiece securely. An insecure workpiece will lead to accident or injury.

◆ Use only the specified accessories and attachments.

Use only the accessories and attachments given in this manual and our catalogs. A failure to do so will lead to accident or injury.

◆ Never touch the saw blade and moving parts until you have confirmed a complete stop.

The saw blade and other parts coast for a while after the switch is turned off. Never touch them while they are moving.

When it is required to touch the saw blade and moving parts for replacement, etc., switch off the machine and unplug it before starting the operation.

If the machine remains plugged in, it will start suddenly, leading to accident or injury.

PIPE SAW 200SP

WARNING

◆ Switch off and unplug the machine in the following cases.

- When not in use or when servicing, cleaning, checking or replacing parts.
- When replacing accessories such as saw blade.
- When hazard is predictable (including a power failure).

If the machine remains plugged in, it will start suddenly, leading to injury.

◆ If you feel something unusual, stop the machine immediately.

Immediately stop the machine if something is wrong with the machine or you have noticed unusual smell, vibration, sound etc. during operation. Refer to "P.18 TROUBLESHOOTING" in this manual and follow the corresponding instructions.

If you use the machine without taking any action, it will overheat, emit smoke or take fire, leading to accident or injury.

If the machine has emitted smoke or took fire, do not disassemble it but have it inspected or repaired by a qualified person.

◆ Keep your work area clean.

Keep your work bench and area tidy and well lit.
Cluttered areas and benches invite injury.

◆ Keep visitors away.

Do not let visitors touch the machine and power cord or operate the machine. All visitors, especially children, should be kept away from the work area to avoid injury.

◆ Do not force the machine.

Use the machine for the intended application only.
It will do a better job and be safer at the rate for which it was designed.
Forcing the machine will not only invite product damage but also lead to accidents.
Avoid forcible usage which will cause the motor to lock. A smoke or fire may occur.

◆ Wear proper apparel.

Do not wear neckties, open-sleeved clothing, knitted gloves, loose clothing or jewelry (such as necklaces). Otherwise you may get caught in moving parts.

Rubber gloves and non-skid footwear are recommended when working in outdoors. Slippery gloves and footwear will lead to injury.

Wear caps or protective hair covering to contain long hair. Otherwise, you may get caught in moving parts.

Wear crash helmets, safety shoes, etc. according to your working environment.

◆ Do not overreach.

Keep proper footing and balance at all times. You may tumble and get hurt.

◆ Remove wrenches and other hand tools.

Before turning on the machine, make sure that hand tools used for inspection or adjustment are removed from the machine.

Accident or injury may occur if you start the machine with hand tools on it.

WARNING

◆ Stay alert.

Watch what you are doing and use common sense while working. Carelessness will lead to accident or injury.

Do not operate the machine when you cannot concentrate on your work, e.g. when you are tired or while under the influence of alcohol, medication or drugs. Otherwise, accident or injury may occur.

◆ Do not abuse the power cord.

Never carry the machine by the cord or yank it from the socket.

Keep the cord away from heat, oil, grease, knives and sharp edges.

Wire the cord with care. Do not run the cord where it may be stamped, caught or damaged by anything. Otherwise, you may get electrical shock or the cord may be shorted to cause a fire.

◆ Maintain the machine with care.

Keep the saw blade sharp and clean for better and safer performance.

If the saw blade used is worn, damaged or improper for an intended purpose, the motor and machine will be overloaded. This may cause the machine to generate heat, emit smoke or cause fire, or you may get injured.

Follow instructions for replacing accessories.

Inspect the power cord and plug before use. If damaged, have them repaired by our sales representative.

Otherwise you may get electrical shock or the machine may be shorted to cause fire.

Keep handles dry, clean and free from oil and grease, which may lead to injury.

◆ Check damaged parts.

Before further use of the machine, a guard or other part that is damaged should be carefully checked to determine that it will operate properly and perform its intended function.

Check the machine for alignment of moving parts, binding of moving parts, breakage of parts, mounting and any other conditions that may affect its operation.

Do not use the machine when its plug and/or cord is damaged.

You may get electrical shock or the machine may be shorted to cause fire.

Do not use the machine if its switch does not turn it on and off.

A guard or other part that is damaged should be properly repaired or replaced by an authorized service center unless otherwise indicated in this instruction manual.

◆ Store the idle machine tidily.

When not in use, machines should be stored in dry and high or locked-up place - out of reach of children.

◆ Have your machine repaired by a qualified person.

Our products are in accordance with the relevant safety rules. Do not modify them.

Repairs should only be carried out by our sales representative.

Otherwise the machine may not show its performance or you may get injured.

◆ If any label applied to the machine, etc. has come off, always ask for a new label and apply it in position.

PIPE SAW 200SP

OPERATING INSTRUCTIONS

- In addition to the general instruction given above, follow the precautions given below before operating the PIPE SAW 200SP.

DANGER

- ◆ **Do not cut a pipe which contains live gas or residual gas.**
Sparks or cutting heat from the motor can cause ignition or explosion.
- ◆ **Do not operate the machine near hazardous materials such as flammable gasoline, gas and thinner.**
They can cause ignition or explosion.
- ◆ **In case to cut a pipe with water remaining inside, avoid being splashed water onto the machine.**
If the machine is splashed, it will lead to electrical shock.
Water will come into the gearbox, and the gears will get damaged.

WARNING

- ◆ **Operate the machine with the voltage indicated in the machine plate.**
If the operating voltage is higher than indicated, the machine will run at abnormally high speed, causing injury. If the operating voltage is higher than indicated, heat, smoke or sparks may be generated.
- ◆ **Before starting operation, fully check for underground objects such as conduit pipes, water pipes and gas pipes near the place of operation.**
If there are such objects, the saw blade may touch any of them and electrical shocks, electric leaks or gas leaks which will cause accidents may occur.
- ◆ **Hold the machine body securely during operation.**
If you do not hold it securely, you may get injured.
- ◆ **If the machine is not in good order or generates unusual noise, immediately switch it off to stop operation and request your sales representative for inspection or repair.**
If you continue to use the machine, you may get injured.
- ◆ **If you have dropped or hit the machine accidentally, carefully check its saw blade, body, etc. for damage, crack or deformation.**
Damage, crack or deformation to the saw blade or machine body will lead to accident or injury.
- ◆ **Before changing the saw blade, always disconnect the power cord.**
Otherwise, the machine will start running suddenly, causing injury.
- ◆ **Install the saw blade to the machine correctly.**
Otherwise, if the saw blade comes off, you may get injured.
- ◆ **During operation, keep your hands, face, etc. away from the saw blade and chip ejector.**
Otherwise, you may get caught by the saw blade, causing an accident or injury.

PIPE SAW 200SP

⚠ CAUTION

- ◆ **When carrying the machine, disconnect the power cord.**
Otherwise, the machine will run suddenly, causing an accident or injury.
- ◆ **Never touch the saw blade, chips and work piece immediately after cutting operation.**
Immediately after cutting operation, they are hot and you can get burnt or injured.
- ◆ **Pay attention not to cut the power cord by the saw blade.**
You may get electrical shock.
- ◆ **Before starting operation at a high place, fully make sure that there is no one under you.**
An accident can occur if you drop a work piece or the machine.
- ◆ **When you cut a pipe near an obstacle such as a wall or an adjacent pipe, leave an enough clearance to prevent the nose of the saw blade from making contact with the obstacle.**
The machine or the saw blade may be broken.

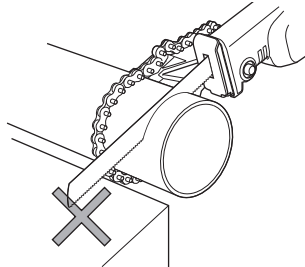

- ◆ **Do not cut the work piece which requires more than capacity.**
If cut the work piece which requires more than capacity the saw blade may be broken.

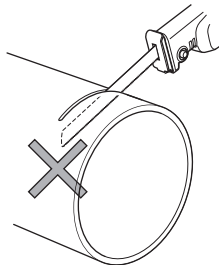

- ◆ **Use the Asada genuine saw blade.**
If use the other saw blade there may be a possibility to cause accidents unexpectedly.

PIPE SAW 200SP

PARTS IDENTIFICATION

Name of Parts

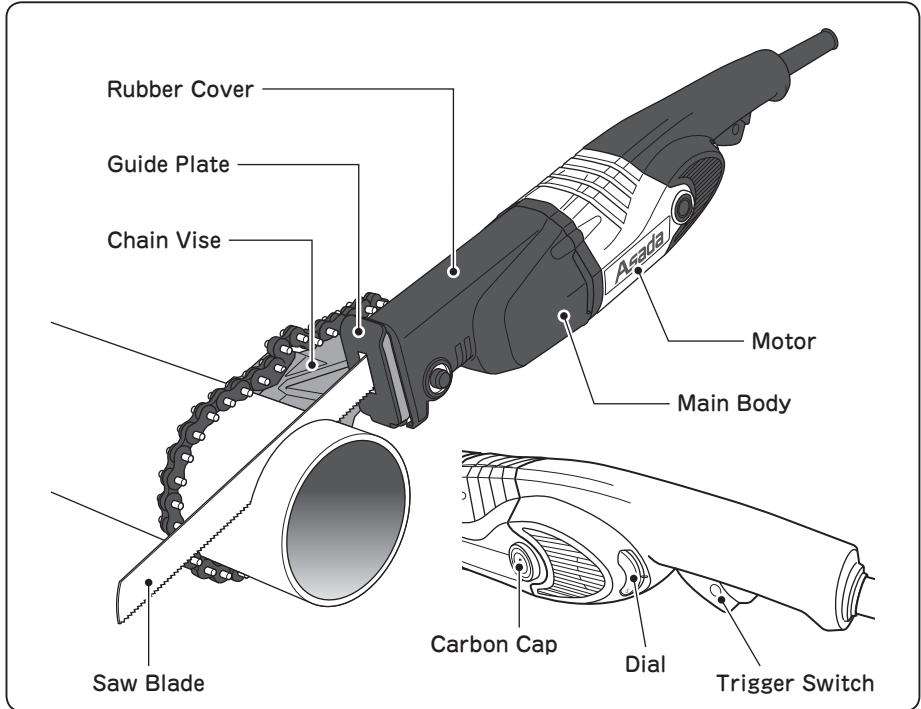

Specifications

Description		PIPE SAW 200SP
Cutting Capacity	Steel pipe	1/2" - 8" *Able to cut 8" pipe with optional saw blade (No.61471 or No.61486)
	Stainless Steel pipe	1/2" - 4" (thickness:4mm or less) 5" - 8" (thickness:3mm or less) *Able to cut 8" pipe with optional saw blade (No.61486)
Motor		Universal Motor ; Single-Phase 1500W 50/60Hz
Stroke		26mm
No-load Stroke/Min		700 - 2060min ⁻¹ (spm)
Weight and Size	Main Body	3.9kg / L480 × W92 × H93mm
	Chain Vise	1.2kg
	Plastic Box	1.9kg / L650 × W305 × H130mm

* Voltage : made to order.

* Specifications will be changed without notice for quality improvement.

PIPE SAW 200SP

Standard Accessories

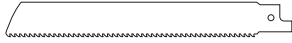

Saw Blade Super HSS
200×8T 1pcs (No.61371)
270×8T 1pcs (No.61459)

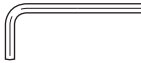

Allen Wrench(4) 1pcs
(No.86002)

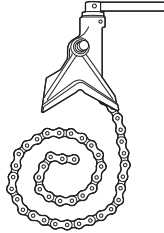

Chain Vise 1pcs
(No.PS480)



Plastic Box 1pcs
(No.PS443)

Optional Accessories

- No.ST014 Threading Oil White 1pcs



- SAW BLADE FOR PIPE SAW 200SP

Code No.	Description	pcs/set	Cutting Capacity	Remarks
61210	Saw Blade 140×8T	5pcs	2"	Steel Pipe, Angle Steel
61305	Saw Blade 200×8T	5pcs	4"	Steel Pipe, Angle Steel
61327	Saw Blade 200×6/8T	5pcs	4"	Steel Pipe, Angle Steel
61337	Saw Blade 290×6/8T	5pcs	6"	Steel Pipe, Angle Steel
61471	Saw Blade 320×6/8T	5pcs	8"	Steel Pipe, Angle Steel
61369	Saw Blade Super HSS 140×14T	5pcs	2"	Stainless Steel Pipe
61370	Saw Blade Super HSS 140×6T	5pcs	2"	Stainless Steel Pipe
61371	Saw Blade Super HSS 200×8T	5pcs	4"	Stainless Steel Pipe
61372	Saw Blade Super HSS 200×6T	5pcs	4"	Stainless Steel Pipe
61458	Saw Blade Super HSS 270×6T	5pcs	6"	Stainless Steel Pipe
61459	Saw Blade Super HSS 270×8T	5pcs	6"	Stainless Steel Pipe
61486	Saw Blade Super HSS 320×6/8T	5pcs	8"	Stainless Steel Pipe
61363	Saber Saw Blade (BI-METAL) 100×18T	10pcs	1"	Stainless Steel Pipe
61358	Saber Saw Blade (BI-METAL) 150×10T	10pcs	2"	Stainless Steel Pipe
61359	Saber Saw Blade (BI-METAL) 150×14T	10pcs	2"	Stainless Steel Pipe
61360	Saber Saw Blade (BI-METAL) 150×18T	10pcs	2"	Stainless Steel Pipe
61361	Saber Saw Blade (BI-METAL) 200×14T	10pcs	4"	Stainless Steel Pipe
61362	Saber Saw Blade (BI-METAL) 200×18T	10pcs	4"	Stainless Steel Pipe
61460	Saber Saw Blade (BI-METAL) 250×14T	10pcs	5"	Stainless Steel Pipe
61461	Saber Saw Blade (BI-METAL) 250×18T	10pcs	5"	Stainless Steel Pipe

PIPE SAW 200SP

PREPARATIONS BEFORE STARTING OPERATION

- Before operating the machine, make the following preparations:

Confirmation of the Earth Leakage Circuit Breaker

Since this product has a double-insulated structure, the law does not require it to install an earth leakage circuit breaker. To prevent electrical shock, however, it is recommended to connect the machine to the power supply which is provided with an earth leakage circuit breaker.

Extension Cord

- ① When an extension cord is required for use with a distant power supply, it should be thick enough to carry certain current and as short as possible to ensure that the product is used with the maximum efficiency without a failure.
- ② Following chart shows maximum length of the extension cord depending on the thickness (sectional area of the core wire) which applicable to the machine.

Sectional area of the core wire	Maximum length
1.25mm ²	10m
2.0mm ²	15m
3.5mm ²	30m

WARNING

- ◆ **The extension cord used should be without damage.**

A failure to do so may result in electrical shock or short, causing a spark.

Maintaining and Checking the Working Environment

Make sure that the working area is kept proper as described in the "SAFETY INSTRUCTIONS" and "OPERATING INSTRUCTIONS".

Noise Prevention Control

- ◎ Noise is controlled as set forth in relevant regulations. The machine must be operated at less than the regulated noise to avoid discomfort to the neighborhood. Sound barriers may be required under some circumstances.

PIPE SAW 200SP

HOW TO OPERATE THE MACHINE

- Before starting operation, always read the instructions in "SAFETY INSTRUCTIONS" and "OPERATING INSTRUCTIONS" (pages 2 to 6).

⚠ WARNING

◆ **Always use the power supply indicated in the machine plate.**

If the operating voltage is higher than indicated, the motor will run at abnormally high speed, which may damage the machine.

If use the machine at over voltage indicated in the machine plate or instruction manual, the machine may become hot, emit smoke or catch fire.

◆ **Make sure that the switch is off before plugging the machine in.**

Pull the Trigger Switch to turn on and release to turn off. Always make sure that the Trigger Switch returns when you release the trigger pulled.

If you insert the plug into the receptacle, not knowing the switch is on, the machine will start abruptly, leading to an unexpected accident.

◆ **In case to use engine generator, use the engine generator which output capacity is more than 2.8KVA with inverter control type.**

If use engine generator without inverter control, the machine will be broken.

How to Set the Saw Blade

⚠ WARNING

◆ **In order to prevent the accident, pull out the plug from the receptacle.**

The machine will start running suddenly, it will lead to accidents or injuries.

⚠ CAUTION

◆ **Never touch the saw blade, chips and work piece immediately after cutting.**

Immediately after cutting operation, they are hot and you can get burnt or injured.

- ① Loosen the Clamp Bolt by Allen Wrench.

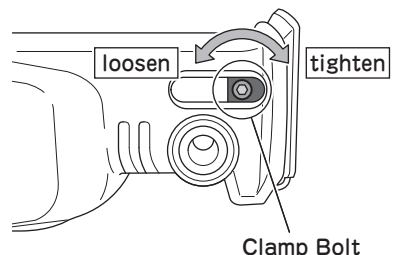

PIPE SAW 200SP

- ② Insert the saw blade between the Blade Holder and the Saw Guide, and put the projection of holder into the hole of blade.

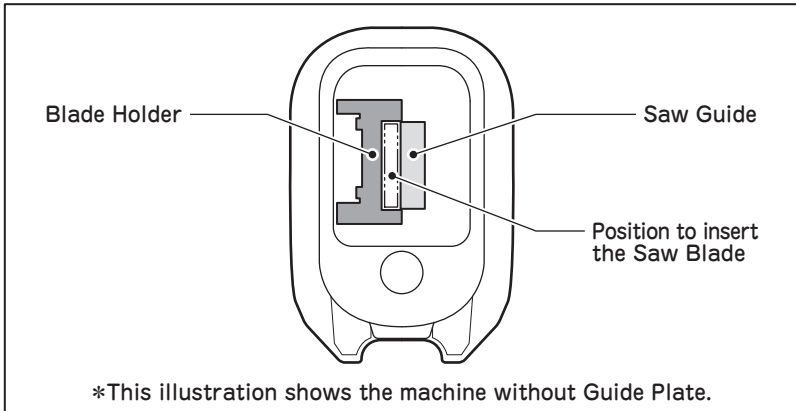
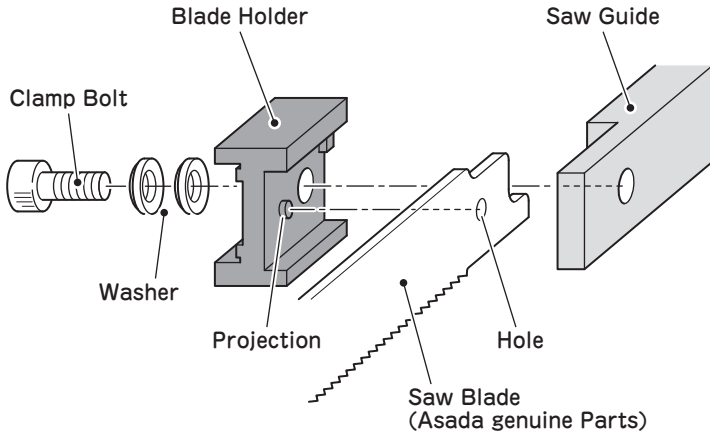

- ③ Softly tighten the Clamp Bolt, and after the confirmation that the saw blade does not come off, tighten it strongly.

⚠ CAUTION

- ◆ If the tightening bolt comes loose, the saw blade will come off and the machine or saw blade will be damaged, causing accidents or injury.

PIPE SAW 200SP

How to Set the Saber Saw Blade

- ① Remove Clamp Bolt and Guide Plate.

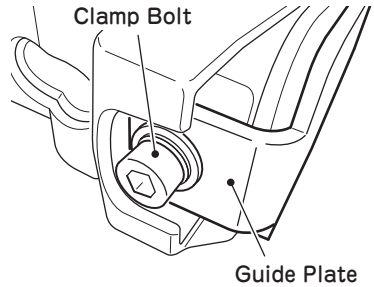

- ② Loosen the Clamp Bolt, take out the Washer.

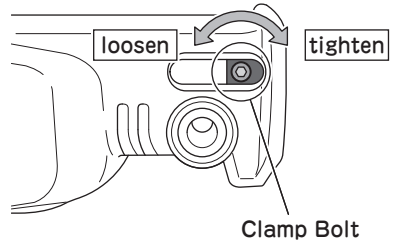

- ③ Take out the Blade Holder.

- ④ Reverse the Blade Holder and tighten it by the Clamp Bolt.

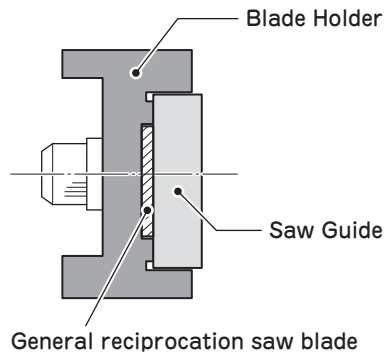
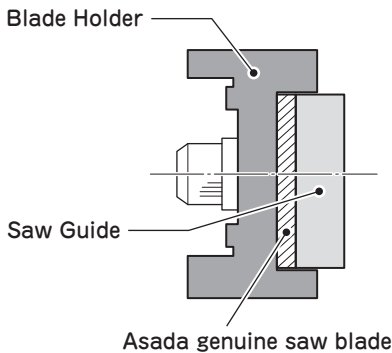

PIPE SAW 200SP

Cutting with Chain Vise

⚠ WARNING

- ◆ Do not run the machine without the saw blade making contact with the work piece.
The saw blade may be broken by oscillation and the broken saw blade may hurt you. Turn on the switch with the saw blade pressing against the work piece.

⚠ CAUTION

- ◆ Do not remove the rubber cover. Always hold the machine body on the rubber cover.
- ◆ Do not fit the chain vise on the cut-off end of the work piece.
Otherwise, the work piece and the machine will drop together after cut.
- ◆ Do not cut a pipe of a large diameter which is over capacity.
Otherwise, the nose of the saw blade may make contact with the inner wall of the pipe, breaking the saw blade.
- ◆ Do not force the machine during cutting. Put light force on it to cut.
Otherwise, the saw blade may be broken or its service life shortened.
- ◆ Fix the work piece securely.
Machine operation without fixing the work piece may cause of unforeseen accident or injury.
- ◆ When cutting stainless steel pipe, use threading oil (Optional accessory: Asada Threading Oil White, No.ST014).
Cutting stainless steel pipe without oil cause of drastically shortened the service life of the saw blade.
- ◆ When operate the machine, take care that contamination like cutting chip, mud, water and so on do not enter into the machine. When contamination collects at Saw Guide, clean it each time.
- ◆ When cut steel pipe, use Chain Vise for stable operation and better performance.

- ① Fix the Chain Vise to the work piece securely. Fix the work piece securely by Vise, if the work piece is not fixed unlike installed pipe.

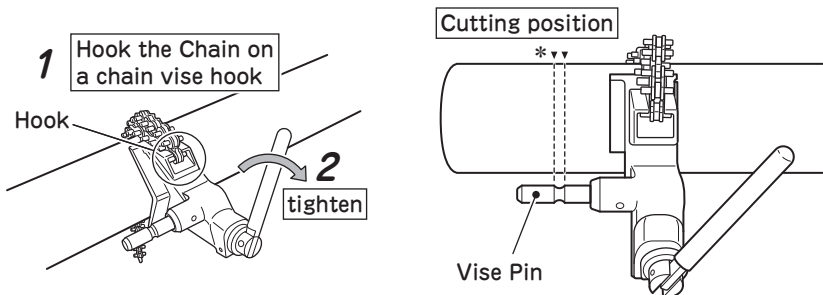

*Cutting point varies depending on mounting position of the pipe saw.

PIPE SAW 200SP

- ② Push the Main Body into Vise Pin. At this time, conform the Vise Pin into the hole of Main Body.
- ③ Loosen the Chain Vise, conform the saw blade at the cutting position, and then again fix it securely.
- ④ Pull the Trigger Switch to turn the machine on with the saw blade pressing against the work piece. Lift the grip up and cut the work piece slowly. For cutting speed, refer to the below chart.

Pull the Trigger Switch to turn the machine on with pressing the saw blade against the work piece.

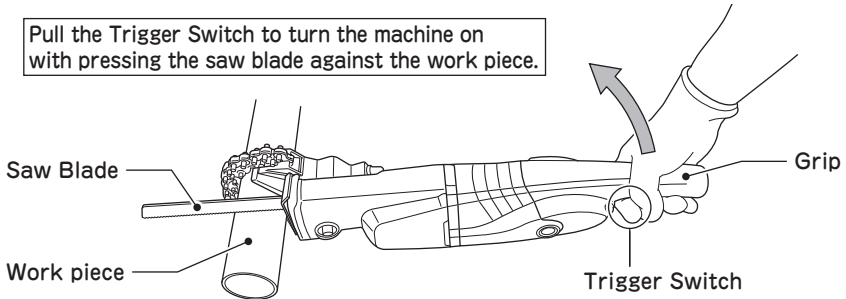

Cutting material	Size	Dial indication	Cutting time
Steel Pipe	2"	6	15sec
	4"		1min
	6"		2min
	8"		4min
Stainless Pipe	2"(t=4)	1 ~ 2	2min
	4"(t=4)		4min
	6"(t=3)		9min
	8"(t=3)		13min

- * Indicated cutting times are averages. It may take longer under the condition of the saw blade and also the cutting material.
 - * Do not operate the machine for long time(over 15 minutes) at low saw blade speed.
 - * Adjust the saw blade speed at cutting condition. If the waggle width of the saw blade is wide or the saw blade chip, adjust the saw blade speed slower.
- ⑤ For removing the main body from the Chain Vise, pull out the main body pushing the end of the Vise Pin with thumb.

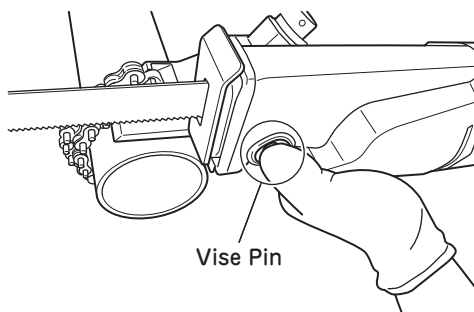

PIPE SAW 200SP

Cutting without Chain Vise

⚠ CAUTION

- ◆ Please use Chain Vise when you cut large size of steel pipe (more than 2 1/2").
Cutting large size of steel pipe (more than 2 1/2") is hard without Chain Vise.
- ◆ Press the Guide Plate against the work piece at cutting.
The saw blade may be broken due to vibration.
- ◆ Hold the machine body and the Grip firmly during cutting.
If not, let go of the machine and cause unforeseen accident.

- ① Put the saw blade at the cutting position of the work piece.
- ② Press the Guide Plate hard against the work piece, then pull the Trigger Switch to turn the machine on.

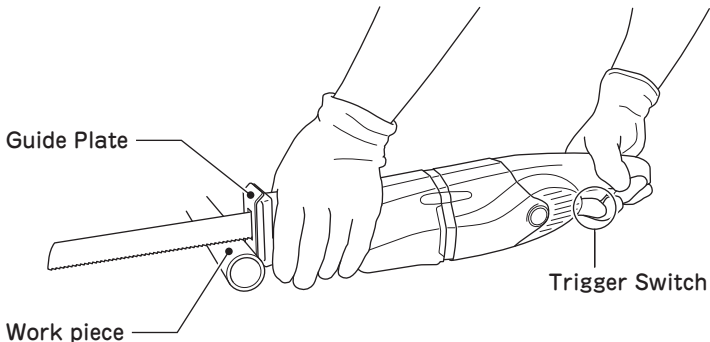

PIPE SAW 200SP

Adjustment of Saw Blade Speed

- This machine is equipped with an electronic control circuit of valuable saw blade speed controller.

The dial indication of "1" denotes the lowest speed and "6" the highest speed.

High speed is suitable for soft steel pipes and low speed for stainless steel pipes. Use the appropriate speed in response to the work piece and operating conditions.

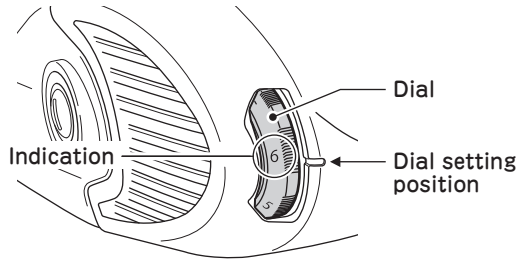

⚠ CAUTION

◆ Adjust the saw blade speed under no load.

It is too dangerous to adjust the saw blade speed during cutting.

◆ Do not operate the machine for long time(over 15 minutes) at low saw blade speed.

The motor will be forced, causing burnout. Especially avoid forcible usage which will lead to a saw blade stop during cutting. Adjust the saw blade speed so that the machine cut the work piece smoothly.

◆ In case of the saw blade chip, operate the machine at lower speed.

If the blade speed is too much high, the saw blade would be chipped.

◆ If the waggle width of the saw blade is wide, adjust the saw blade speed lower.

If the waggle width of the saw blade is wide, the saw blade would be broken before cutting.

The Over-Load Protector

- The machine is equipped with Over-Load Protector.
To protect the motor, the motor automatically stops at following conditions;
 - When the motor gets heated up to the certain temperatures.
 - When the unit is operated with overloaded continuously.
 - When the motor is locked caused by the stuck blade during cutting operation.
 - At over current caused by low voltage.

In those cases, wait until the motor is cooled down. After the motor is fully cooled down, the unit can be used again.

- For a stainless steel pipe cutting operation, select lower speed(Dial 1-2).
Over Load Protector may be worked due to overloaded if trying to cut too fast.

PIPE SAW 200SP

DAILY INSPECTION AND CARE

⚠ WARNING

◆ **Before starting inspection or maintenance, always turn the switch off and disconnect the attachment plug from the receptacle.**

The machine will start running suddenly, it will lead to accident or injury.

● Check, clean and repair / replace the following areas regularly.

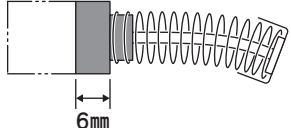
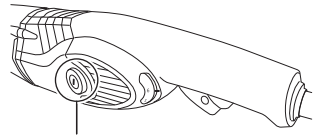
Maintenance & Inspection	Action
Check the plug and power cord for damage.	Replace if any damage is found.
Check the saw blade for chipping or damage.	Replace if chipping is found. (For the saw blade replacing procedure, refer to page 10 "How to Set the Saw Blade".)
Check Carbon Brushes.	<p>If the length of Carbon Brushes wear down to around 6mm, it must be changed. Change both of left and right to new ones at the same time. (Code No.PS413 Carbon Brush set for PS200SP)</p> 
	<p>How to change</p> <ol style="list-style-type: none"> ① With a minus driver, take off the Carbon Cap at the Motor Case. ② Take out the Carbon Brushes and change them to new ones with care not to make the new ones dirty by oil.  <p style="text-align: center;">Carbon Cap</p>
Check if screws are loosen and tight them up if needed.	Retighten any loosed screws.
How to handle the motor.	The coil of the motor is the heart of the machine. Handle with extreme care to protect it from scratches and not to be exposed to cleaning oil and water. Dirt and dust accumulating in the motor will cause a failure. After operation of about 50 hours, run the motor under no load and blow non-humid air through the wind hole of the housing. This helps remove dirt and dust.
Check the Saw Guide carefully that there is no chips, mud, sand, water and so on.	If chips, mud, sand, water, etc. remain sticking to the Saw Guide, the Saw Guide will rust and lead to a failure. Always clean the Saw Guide before storing the machine.
Remove stain from the machine and keep clean.	The outer frame of the machine is made of rigid synthetic resin. However its surface will be damaged by gasoline, thinner, petroleum and kerosene. When cleaning, wipe its surface with a dry cloth or a cloth immersed in soap suds.
Keep them in safe and dry places.	<p>Do not store the machine at following places:</p> <ul style="list-style-type: none"> · At children can reach and take the machine easily. · At exposed to rain or humidity. · At sudden temperature changes. · Under direct sunlight. · Near volatile material which may ignite or explode.

PIPE SAW 200SP

TROUBLESHOOTING

- Before asking for repairs, check following troubleshooting.
If the problem cannot be solved, contact with the shop you purchased or our sales office.
- Troubles due to misuse or improper applications are not covered by warranty.

Phenomenon	Cause	Measures
Power Issue / Machine not working	Damaged Power Cord	Replace the power cord if damages are found.
	Low voltage	When the extension cord is too long or too thin, see "Extension Cord" on P9 and use a proper extension cord.
	Working Over-load Protector	Make sure that the motor is cooled down enough, and then turn on the switch again.
Insufficient power	Low voltage	When the extension cord is too long or too thin, see "Extension Cord" on P9 and use a proper extension cord.
The Saw Blade is broken, and/or is loose	Loosed Clamp Bolt of Blade Holder	Re-tighten Clamp Bolt.
	Forcing the machine to cut	Do not cut by force. Cut slower.
	Unfixed Chain Vise	Fix the Chain Vise to the work piece firmly.
The machine stops during cutting	Low voltage	When the extension cord is too long or too thin, see "Extension Cord" on P9 and use a proper extension cord.
	Working Over-load Protector	Make sure that the motor is cooled down enough, and then turn on the switch again. Do not cut by force. Cut slower.
	Worn out Carbon Brushes	If Carbon Brushes are worn down to around 6mm, they must be changed.
	Worn out saw blade	If the saw blade is worn out, cannot cut properly. Change the saw blade to new one.
Oblique cutting	Worn out saw blade	If the saw blade is worn out, it causes of oblique cutting. Change the saw blade to new one when it's worn out.
	Jammed contaminations between Chain Vise and the work piece	Remove the contamination jammed between Chain Vise and the work piece.
	Forcing the machine to cut	Do not cut by force. Cut slower.

Noise/vibration information

Measured in accordance with EN 60745-2-22

Model no. : PS201SP,PS202SP

Noise level: L_{pA} : 82.2dB(A) L_{wA} : 93.2dB(A) K= 5dB(A)

Vibration level: $a_{h,B}$ = 24.4m/s² K = 1.5m/s² (the work mode description "cutting boards")
 $a_{h,WB}$ = 24.4m/s² K = 1.5m/s² (the work mode with "cutting wooden bean")

The vibration emission level has been measured in accordance with a standardised test given in EN 60745; it may be used to compare one tool with another and as a preliminary assessment of exposure to vibration when using the tool for the applications mentioned

- using the tool for different applications, or with different or poorly maintained accessories, may significantly increase the exposure level
- the times when the tool is switched off or when it is running but not actually doing the job, may significantly reduce the exposure level

! protect yourself against the effects of vibration by maintaining the tool and its accessories, keeping your hands warm, and organizing your work patterns

CE Declaration of Conformity

- We declare under our sole responsibility that this product is in conformity with the following standards or standardized documents: EN 60745, EN 61000, EN 62841, EN 55014 in accordance with the regulations 2006/95/EC, 2014/30/EU, 2006/42/EC, 2014/30/EU
- Technical file at: ASADA Corporation, 3-60 Kamiida, Nishi-machi, Kita-ku, Nagoya, Aichi, Japan

Yoshihiro Ishizaki
Quality Assurance Manager



ASADA CORPORATION
3-60 Kamiida, Nishi-machi, Kita-ku, Nagoya, Aichi, Japan 25/10/2018

● Customer Memo

Please fill in for your record in the future
The information is helpful for inquiry and ordering parts.

Products Number :
Date Purchased :
Store Purchased the Unit :

Asada
ASADA CORPORATION

3-60, Kamiida, Nishi-Machi, Kita-Ku, Nagoya, Japan 462-8551

TEL +81-52-914-1062

FAX +81-52-914-1065

URL <http://www.asada.co.jp>

E-mail: trade@asada.co.jp

Code No. IM0349

Ver.06 LE