

Asada

AIR CONDITIONING TOOL

VACUUM PUMP *Eco* SERIES

INSTRUCTION MANUAL

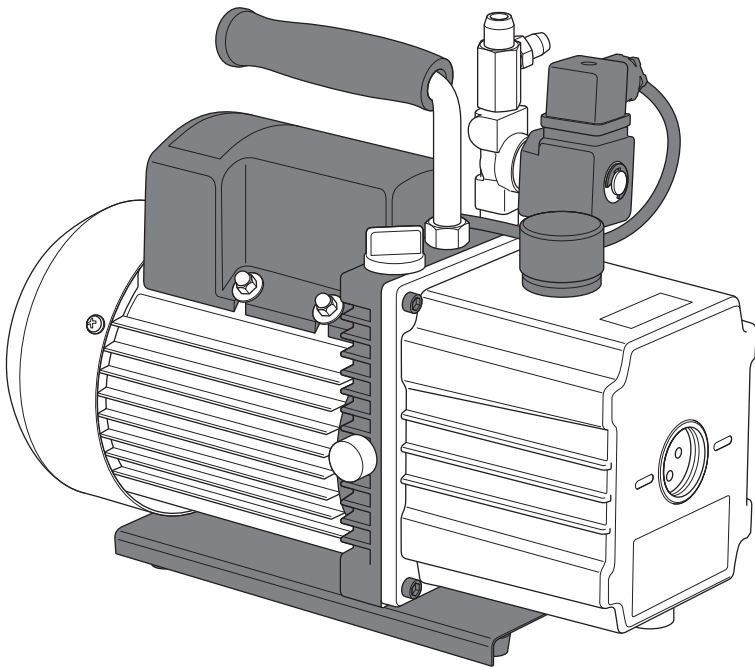

[Read through this manual carefully before using the pump.]

Ver.3

VACUUM PUMP

SAFETY PRECAUTIONS

Thank you for choosing our Vacuum Pump *∞* series.

- This instruction manual must be retained by the user of this pump.
- Read this instruction manual carefully and completely before use and thoroughly understand the usage, capacity, cautions and maintenance for correct operation.
- Handle the pump properly to make full use of its functions for safe work.
- After reading the instructions, save this manual so that you can read it when necessary.
- Use the pump for the intended application only. It will do a better job and be safer at the rate for which it was designed.
- Upon receiving the pump, check the following.
 - Check that the pump is built conforming to the specifications stated in your order.
 - Check the overall pump for any damage or deformation caused in transit due to accidents or other reasons.
 - Check that all items and accessories delivered.

In case any discrepancy is found, immediately report the fact to the shop you purchased or our sale office. (The contents of this manual are subject to change without prior notice.)

CLASSIFICATION OF CAUTIONS

Precautionary signs are classified into the following 2 levels.



Indicates a potentially hazardous situation which, if not avoided, could result in death or serious injury.



Indicates a potentially hazardous situation which, if not avoided, may result in minor or moderate injury. It may also be used to alert against unsafe practices.

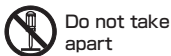

Do not take apart



Rotation parts



Burn injury

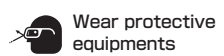

Wear protective equipments



220V



Electric shock



Fire



Explosion



Other

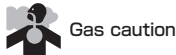

Gas caution

CONTENTS

SAFETY PRECAUTIONS	2	MAINTENANCE & INSPECTION	11
COMPONENTS OF THE MACHINE ...	5	Oil Check	11
Main Parts	5	Oil Change	11
Specifications	6	Vacuum Level Check	12
Standard Accessories	6	Oil Application	12
Optional Accessories	6	Ambient Temperature	12
HOW TO USE	7	BEFORE ASKING FOR REPAIRS	13
Preparation	7		
Performance Test	8		
For Effective Operation	8		
Vacuuming	9		

VACUUM PUMP

CAUTIONS IN USE

- Basic cautions to use the pump safely are listed in this section.
- The detailed cautions in operation are described in each chapter.

WARNING



◆ Only qualified persons are allowed to disassemble the pump.

◆ Do not modify the pump.

It may lead to mechanical failure or accident.



◆ Do not put a finger or a stock to the turning part of motor.

It may lead to accident or injury.



◆ Do not touch the pump part during or soon after operation.

The pump part becomes hot and it may lead to burn injury.



◆ Wear protective glasses and gloves during operation.



◆ The power source should be AC220-240V.

If the power source is not correct, it may lead to heating, smoking or fire.
See the specification in this instruction manual.



◆ Do not operate the pump in rain or with wet hands.

Operation in rain or with wet hands may lead to electric shock.

◆ Always ground the pump.

If the pump is not grounded, it may lead to electric shock or mechanical failure.



◆ Always inspect the power plug and plug in securely.

A dirty plug and incomplete connection may lead to electric shock or fire.

VACUUM PUMP

WARNING



◆ Do not use the power cord concurrently with other electrical equipments and avoid overload connection.



◆ Do not pull the power cord to disconnect from the outlet.

It may lead to electric shock, fire or injury.



◆ Do not use the pump in an area where gasoline, thinner or any other combustible gas may exist.

It may lead to explosion or fire as the pump has sparks in starting or during operation.



◆ When unattended, blackout or servicing, switch off and unplug the pump.

The pump will start suddenly and it may lead to accident.



◆ The pump should be used in a well-ventilated area especially in a small space.

Otherwise an accidental lack of oxygen or poisoning may happen.



◆ Use or store the pump on a level place.

The oil may leak and it may lead to accident.



◆ Be careful about oil leakage. Make sure no vacuum pump oil leaks.

It may lead to fire.

VACUUM PUMP

CAUTION



- ◆ **An extension cord used should be a three-core cable with a length of 10m or less when its diameter is 2.0mm².**

An unsuitable extension cord (too thin or too long) may lead to starting failure or fire.

- ◆ **Do not let visitors touch the pump.**

The pump should be used by a person who read through the instruction manual and understands it completely.

- ◆ **Do not use the pump for purposes other than the original intent.**

This pump is designed to evacuate air from systems or recovery cylinders.



- ◆ **Do not use the pump when the result is unpredictable.**

- ◆ **Do not overload the pump.**

It will lead to mechanical failure or accident.

- ◆ **Keep your work bench and area tidy and well lit.**

Bad working conditions invite accidents.

- ◆ **Do not operate the pump when you cannot concentrate on your work due to fatigue, drinking, medication and so on.**



- ◆ **When not in use, the pump should be stored in dry and high or locked-up place – out of reach of children.**

- ◆ **Use only the accessories or attachments given in this manual and our catalogs.**

Otherwise it will lead to accident or mechanical failure.



- ◆ **If you have dropped or hit the pump accidentally, carefully check for damage, crack or deformation.**

- ◆ **Always check for deformation, corrosion and so on in each part of the pump.**



- ◆ **Immediately stop the pump if something is wrong with the pump (unusual smell, vibration, sound) and refer to “BEFORE ASKING FOR REPAIRS” . Do not disassemble the pump without reason and ask for repairs.**

Contact our authorized distributors for repairs.

VACUUM PUMP

COMPONENTS OF THE MACHINE

Main Parts

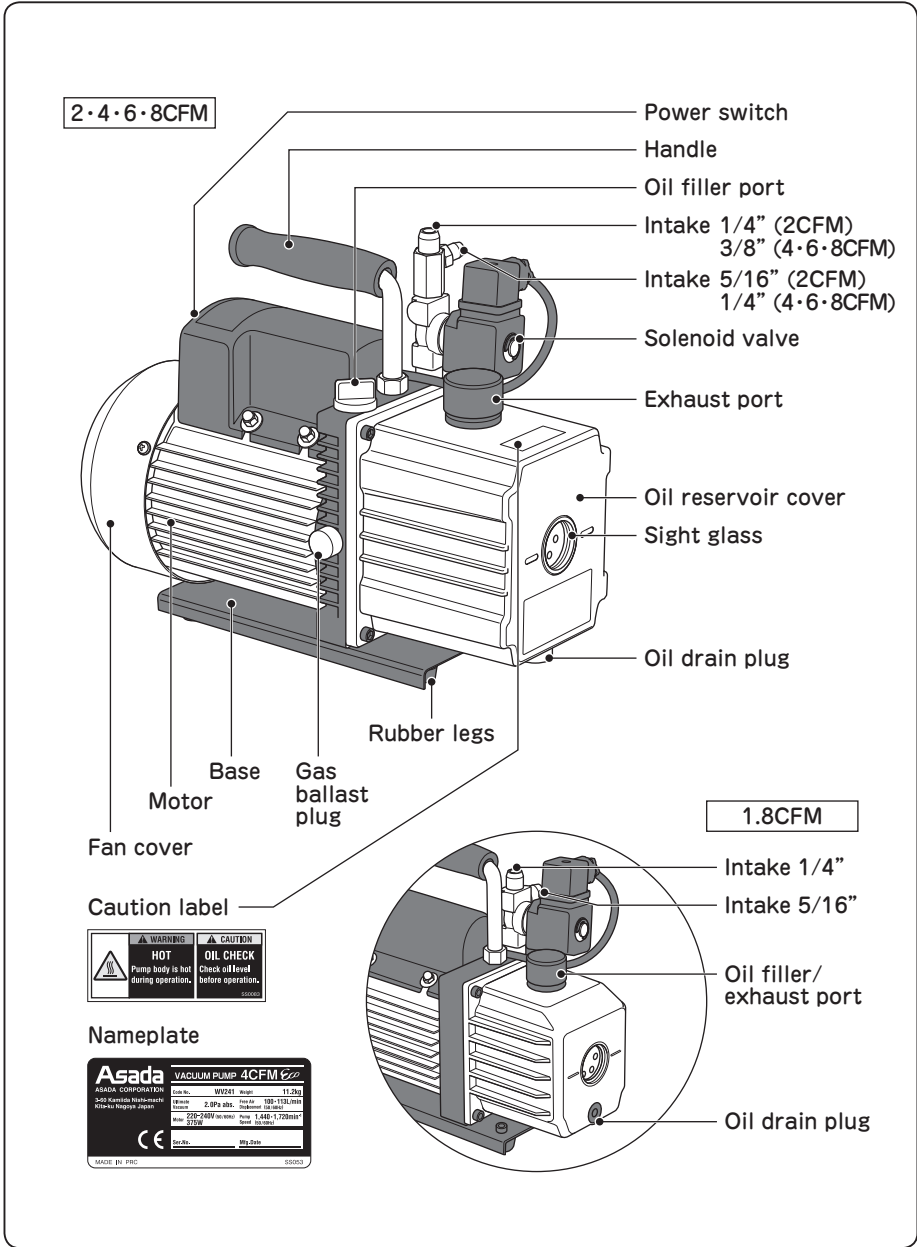

VACUUM PUMP

Specifications

Item	Vacuum pump				
	1.8CFM Eco	2CFM Eco	4CFM Eco	6CFM Eco	8CFM Eco
Code No.	WV211	WV221	WV241	WV261	WV281
Pump	2-stage				
Exhaust rate (50/60Hz)	42/50L/min	51/57L/min	100/113L/min	142/170L/min	198/226L/min
Ultimate vacuum	3Pa abs. (25micron)	2Pa abs. (15micron)			
Pump speed (50/60Hz)	2,880/3,440min ⁻¹	1,440/1,720min ⁻¹			
Motor 220-240V	200W	250W	375W	550W	550W
Oil capacity	150ml	260ml	390ml	580ml	460ml
Intake	1/4, 5/16	1/4, 5/16	1/4, 3/8	1/4, 3/8	1/4, 3/8
Weight	5.0kg	9.4kg	11.2kg	16.5kg	17.0g
Dimensions (L × W × H)	260 × 105 × 200mm	308 × 124 × 230mm	335 × 138 × 265mm	390 × 145 × 290mm	395 × 153 × 300mm

Standard Accessories

Item	Code No.	1.8CFM Eco	2CFM Eco	4CFM Eco	6CFM Eco	8CFM Eco
Vacuum pump oil 230ml	WV014	○	—	—	—	—
Vacuum pump oil 350ml	WV002	—	○	○×2	○×2	○×2
Adapter for different diameter 1/4"female x 5/16"male	Y06114K	—	—	○	○	○
Instruction manual	IM0037	○	○	○	○	○
Adapter for different diameter 1/4"female x M10male	Y06101K	○	○	○	○	○

Optional Accessories

Item	Code No.	Item	Code No.
Vacuum pump oil 500ml	VP3205	5/16" Valve core remover	AP303
Vacuum pump oil 1.0L	VP3210	Digital vacuum gauge	Y69086
Vacuum pump oil 4L	VP3240		
1/4" Valve core remover	AP302		

VACUUM PUMP

HOW TO USE

Preparation

- ① Remove the cap of oil filler port (exhaust port).
 - ② Fill with vacuum pump oil until oil level is a little higher than the bottom of sight glass.
- ※ Use a funnel for oil filling.

⚠ CAUTION



- ◆ Excessive oil can result in overflowing of oil from exhaust/oil filler port.

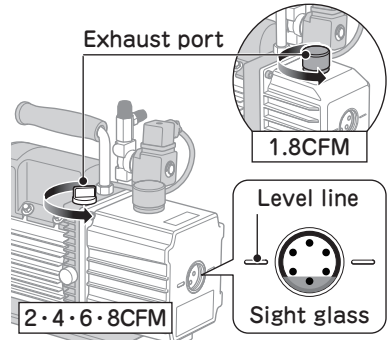

- ③ Put the cap of oil filler port (exhaust port) back.
- ④ Remove the cap of intake.
- ⑤ Plug in a socket.
- ⑥ Switch on the pump and run for about 30 seconds until the pump reaches running speed.
- ⑦ Put the cap of intake back.
- ⑧ After running for about 1 minute, check if oil level reaches the level line on the sight glass. Refill oil if necessary.

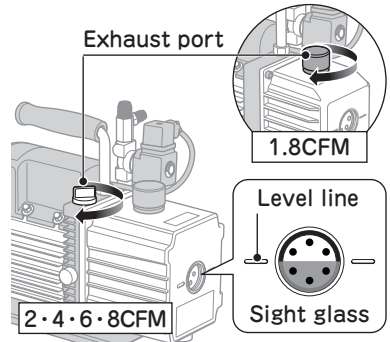

⚠ CAUTION



- ◆ Insufficient oil will result in poor vacuum performance.
- ◆ The pump may not start when the temperature of the pump and oil is 5°C or less.
Warming up is necessary in the area where the temperature is 5°C or higher.
- ◆ The pump may not restart soon after shut-off. Wait for a while and switch on the pump again.

- ⑨ Switch off the pump.

VACUUM PUMP

Performance Test

1) Simplified test method

- ① Connect the low pressure side of manifold to intake of vacuum pump with a charging hose.
- ② Close the low pressure side valve of manifold.
- ③ Switch on the pump and check if the low pressure gauge of manifold indicates " - 0.09 ~ - 0.1MPa" within 30 seconds.
- ④ Switch off the pump.

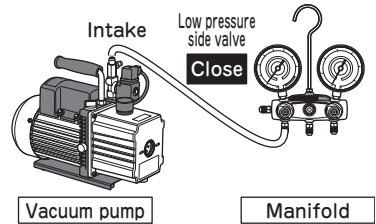

2) Accurate test method

- ① Connect electronic vacuum gauge to intake of vacuum pump.
- ② Switch on the pump and check if the reading is 13.33Pa (100 micron) after 20 ~ 30 minutes.

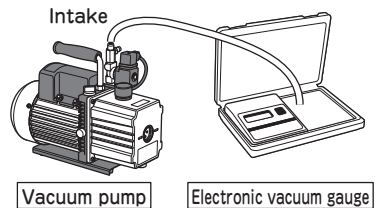

For Effective Operation

- ① The charging hose between the pump and the system should be as short as possible and its diameter should be as large as possible. ($1/4" < 3/8" < 1/2"$)
- ② Vacuum speed can be improved by removing the valve core of system and the core depressor of charging hose.

Remove valve core

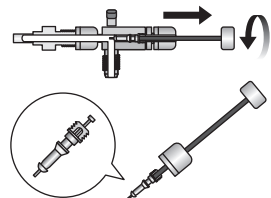

Improve vacuum speed

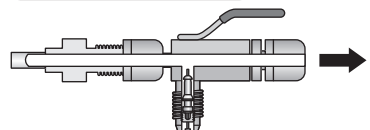

※ Optional accessories

Y18975 1/4" Quick charging valve A

Y18985 5/16" Quick charging valve A

VACUUM PUMP

Vacuumping

1) Vacuumping

- ① Close the low and high pressure side valves of manifold.
- ② Connect the charging hoses as below.

※ In case of vacuumping from piping for R410A, attach the provided Y06114A Adapter for different diameter 1/4" female x 5/16" male to intake.

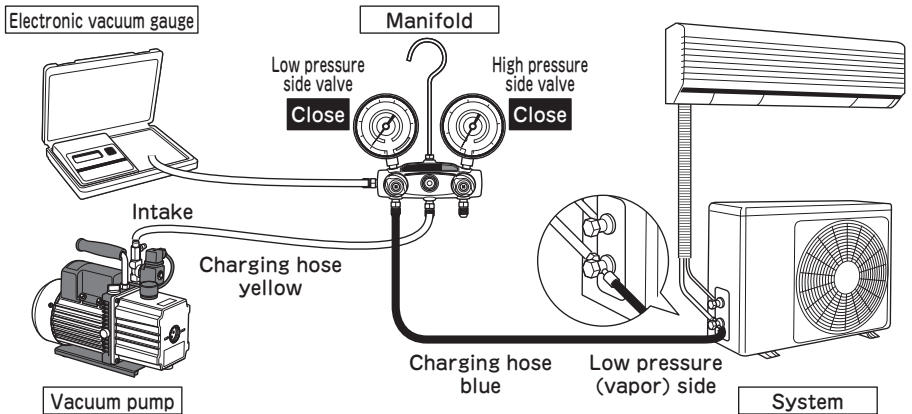

- ③ Open gas ballast plug. (except 1.8CFM)
- ④ Plug in a socket and switch on the pump.

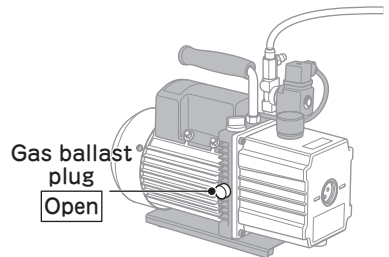

⚠ CAUTION



◆ Always ground the pump.

If the pump is not grounded, it may lead to electric shock in case of mechanical failure or electrical leakage.

VACUUM PUMP

- ⑤ Open the low pressure side valve of manifold slowly.
- ⑥ Close gas ballast plug when the reading on electronic vacuum gauge is 133.3 ~ 266.6Pa (1000 ~ 2000 micron). (except 1.8CFM)

※ Gas ballast plug should be closed to lower vacuum level.

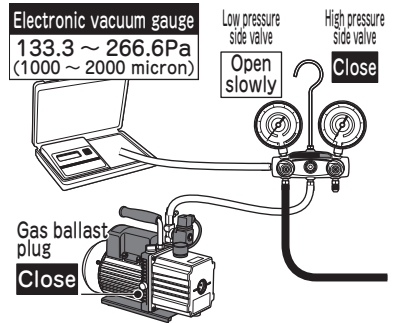

- ⑦ Keep running the pump and close the low pressure side valve of manifold when reaches to the required vacuum level.
- ⑧ Switch off the pump.

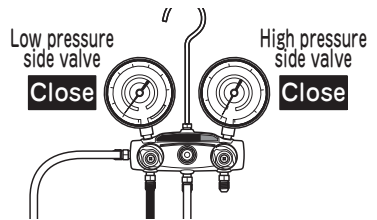

⚠ CAUTION



◆ Disconnect the plug after operation.

◆ Do not upset the pump during operation or transportation.

Oil leaks from exhaust/oil filler port.

VACUUM PUMP

MAINTENANCE & INSPECTION

- Inspect and clean regularly as instructed below and perform correction or replacement timely.

Oil Check

- Always check oil level before operation.
- Change oil every 20 hours operation.
- Change oil after every operation when the pump is used for an old system.
- Use Asada genuine oil for best performance.

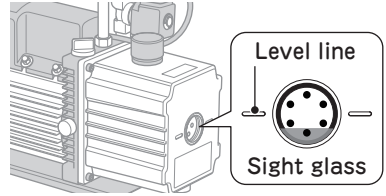

Oil Change

1) Warming up

- ① Remove the cap of intake.
- ② Run the pump to warm up oil.

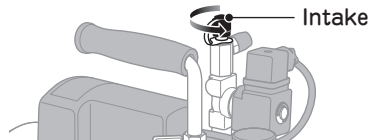

2) Oil drain

- ③ Switch off the pump.
- ④ Remove oil drain plug and tilt the pump to drain oil.
- ⑤ Put oil drain plug back.

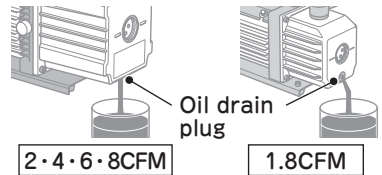

3) Oil filling

- ⑥ Remove the cap of oil filling port (exhaust port).
 - ⑦ Fill new oil until oil level is a little higher than the bottom of sight glass.
 - ⑧ Put the cap to oil filling port (exhaust port) back.
 - ⑨ Switch on the pump, put the cap to intake and keep running the pump for 1 minute.
 - ⑩ Check if oil reaches to the level line. If necessary, refill oil while running the pump.
- ※ When oil is contaminated with sludge or water, remove oil reservoir cover and clean inside the reservoir before filling new oil.

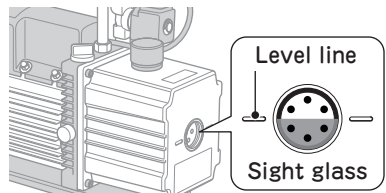
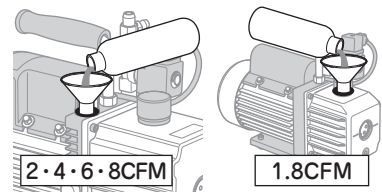

VACUUM PUMP

Vacuum Level Check

- Check the vacuum level of pump with electronic vacuum gauge regularly.
- Change oil regularly.

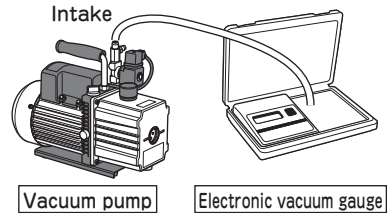

Oil Application

- Apply vacuum pump oil to the O-ring of intake cap and the gasket of exhaust/oil filling port.

Ambient Temperature

- Pump may not start unless the temperature is 5°C or higher.

VACUUM PUMP

BEFORE ASKING FOR REPAIRS

- Refer to the following failure diagnosis before asking for repairs.

Contact our authorized distributors for repairs.

Symptom	Cause	Solution
The pump will not start.	<ol style="list-style-type: none">① The power cord is not plugged in.② The voltage is too low. (within $\pm 10\%$)③ The ambient temperature is too low.④ Poor wiring connection.⑤ The pump is locked.⑥ Motor failure.	<ol style="list-style-type: none">① Plug in the power cord.② Use a shorter extension cord.③ Warm up the pump in doors.④ Repair.⑤ Repair.⑥ Repair.
The pump will not pull enough.	<ol style="list-style-type: none">① Leaking from the system.② Gas ballast plug is not closed.③ Insufficient oil.④ Dirty oil.⑤ Pump parts are worn out.⑥ Damaged fittings, gaskets and seals.⑦ Motor failure.	<ol style="list-style-type: none">① Repair the system.② Close gas ballast plug.③ Refill or change oil.④ Clean reservoir and change oil.⑤ Repair.⑥ Repair.⑦ Repair.
Oil leakage.	<ol style="list-style-type: none">① Damaged gaskets and shaft seals.② Damaged O-ring of oil drain plug.③ Oil drain plug is loose.	<ol style="list-style-type: none">① Repair.② Replace O-ring.③ Tighten Oil drain plug.
Abnormal noise.	<ol style="list-style-type: none">① Motor failure.② Bearing failure.③ Loose bolts.④ Pump failure.⑤ Air is sucked.	<ol style="list-style-type: none">① Repair.② Repair.③ Tighten bolts.④ Repair.⑤ Tighten caps and connections. Replace gaskets and O-rings. Replace fittings or re-seal them.

VACUUM PUMP

● CUSTOMER NOTE

Please enter the following for future use.

This note will be useful in making inquiries and placing purchase orders for parts.

Serial No. :
Date of Purchase :
Sales Representative :

Asada
ASADA CORPORATION

3-60, Kamiida, Nishi-Machi, Kita-Ku, Nagoya, Japan 462-8551

TEL +81-52-914-1062

FAX +81-52-914-1065

URL <http://www.asada.co.jp>

E-mail: trade@asada.co.jp