

# Asada

Bolt Threading Machine

# ***BOLT MACHINE 25Pro***

## **INSTRUCTION MANUAL**

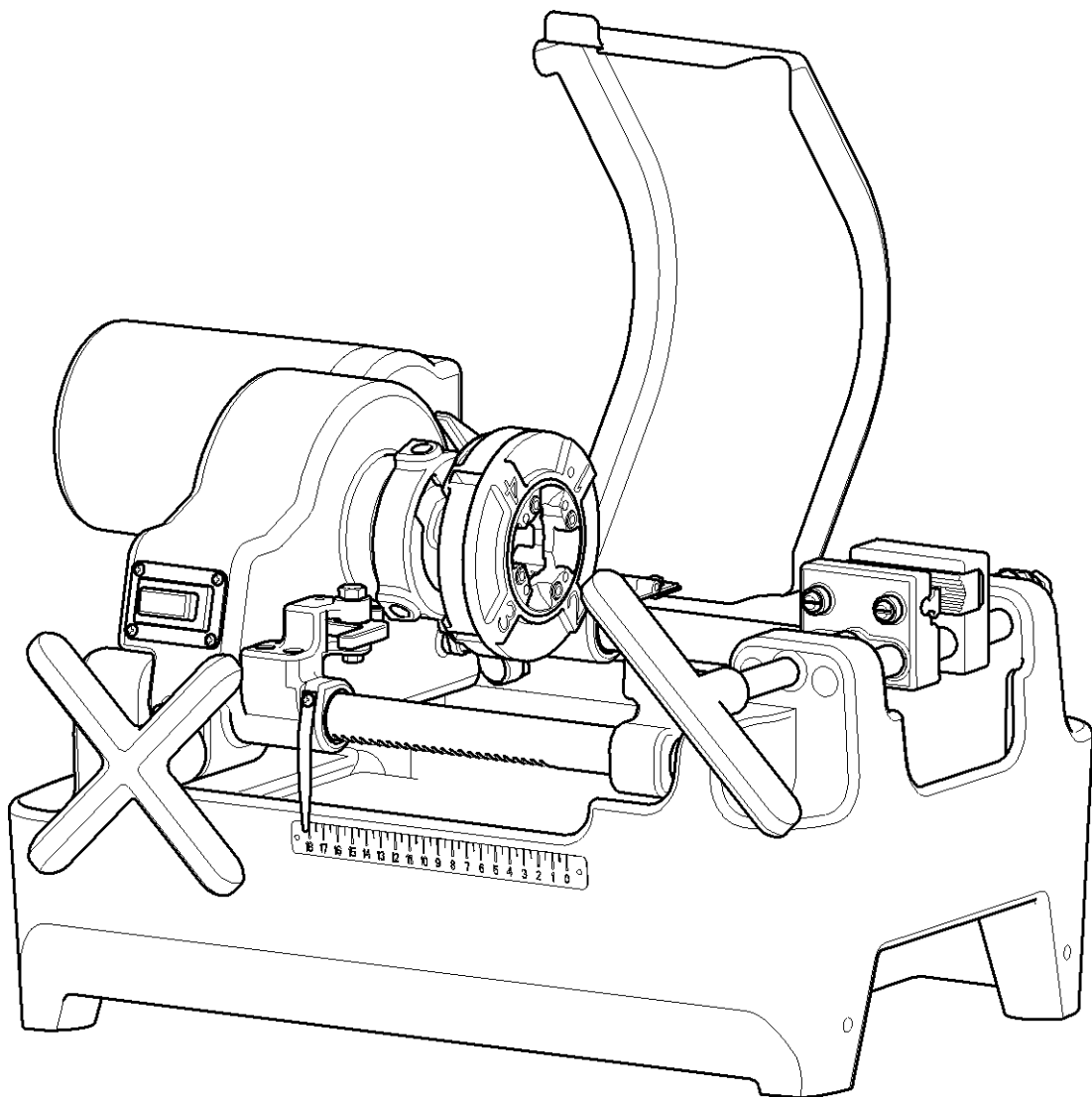

**[Read through this manual carefully before using the machine]**

IM1401

# BOLT MACHINE 25Pro

## SAFETY PRECAUTIONS

Thank you for choosing our BOLT MACHINE25 Pro.

- \* This Instruction Manual must be retained by the user of this machine.
- \* Read this Instruction Manual carefully and completely before use and thoroughly understand the usage, capacity, cautions, and easy repairs for correct operation.
- \* Handle the machine properly to make full use of its functions for safe work.
- \* After reading the instructions, save this manual so that you can read it when necessary.
- \* Use the machine for the intended application only. It will do a better job and be safer at the rate for which it was designed.
- \* Upon receiving the machine, check the following.
  - Check that the machine is built conforming to the specifications stated in your order.
  - Check the overall machine for any damage or deformation caused in transit due to accidents or other reasons.
  - Check that all items and accessories delivered.

In case any discrepancy is found, immediately report the fact to the shop you purchased or our sale office. (The contents of this manual are subject to change without prior notice.)

## CLASSIFICATION OF CAUTIONS

Precautionary signs are classified into the following 3 levels.



Indicates an imminently hazardous situation which, if not avoided, will result in death or serious injury.



Indicates a potentially hazardous situation which, if not avoided, could result in death or serious injury.



Indicates a potentially hazardous situation which, if not avoided, may result in minor or moderate injury. It may also be used to alert against unsafe practices.

## SYMBOLS



Electric shock



Cutting Blade



Toxic Gas



Mask



Explosion



High Temperature



Splashing



Earth



Rotation parts



Fire



Falling



Other



Instruction manual

## CAUTIONS IN USE

### ⚠ DANGER

#### Electric Shock



- Always ground the machine to avoid electric shock or resultant death.
- Do not touch the plug with wet hands.
- Do not expose the machine to rain and water and do not use it in damp or wet locations. Humidity will deteriorate motor insulation or lead to electric shock.

#### Earth



- Immediately replace Power Plug, Power Cord or extension cord, if damaged.
- Do not hold the Power Cord and pull it to disconnect from the receptacle and do not put the machine on the cord and damage it.
- An extension cord used should be a three-core cable having an earth wire. Use a thick and durable cord for outdoor use.

#### Toxic Gas



- Toxic gas is generated. Do not burn the threading oil. In case anyone should inhale the gas, move the person to a place of fresh air, and consult a doctor without a delay.

#### Rotating parts



- The Die-Head will rotate during working. Loose clothing can get easily tangled into moving parts.

### ⚠ WARNING

#### Fire



- Always use the machine at the voltage indicated on Machine Plate. Otherwise, the machine may become hot, emit smoke or catch fire.
- Do not force the machine in a manner that the motor stops due to an overload such as a worn Dies.
- Do not handle or use the threading oil near a fire.
- Immediately replace the Power Plug, Power Cord and extension cord, if damaged.
- If the machine has emitted smoke or took fire, do not disassemble it but have it inspected or repaired by a qualified person.

#### Explosion



- Never install an earth wire to the gas pipe. If attempted, explosion may take place.
- Do not use the machine in the presence of flammable liquids or gases such as gasoline and thinner. Otherwise, ignition or explosion may take place.

# BOLT MACHINE 25Pro

## WARNING

### Cutting blade



- Always wear gloves when replacing Dies. Otherwise, you may cut your hands.
- Cut surfaces are very sharp and do not touch them with your hands.
- When it is required to touch the saw blade and moving parts for replacement, etc., switch off the machine and unplug it before starting that operation.

### Rotating parts



- Before plugging the machine in, always make sure that the switch is OFF. If the machine remains plugged in, it will start suddenly, leading to unexpected accident or injury.
- During operation, keep your hands and face away from the moving parts. You may be caught in the moving parts, causing injury.
- Do not use gloves for works such as threading.
- You may be caught in the moving parts, causing injury.
- Do not wear neckties, open-sleeved clothing, knitted gloves, loose clothing or jewelry (such as necklaces). Otherwise, you may get caught in moving parts.
- Wear caps or protective hair covering to contain long hair. Otherwise, you may get caught in moving parts.
- When not in use or when servicing, cleaning, checking or replacing parts, switch off and unplug the machine. If the machine remains plugged in, it will start suddenly, leading to accident or injury.

### Splashing



- Wear safety glasses while operating the machine. Threading oil or chips enter your eyes and nose.
- Do not blow off chips using air. They may get into your eyes and loss of eyesight may result.

### Masks



- Use a face or dust mask if operation creates dust. Sawdust and dirt may enter your eyes and nose.

## WARNING

### High Temperature



- Immediately after threading, Dies, chips and threaded surface are hot. Do not touch them directly with hands.

### Other



- Fix Spindle Case to avoid moving while carrying the machine, hold and lift the bottom of the machine.
- When lifting the machine, bend your knees to avoid a load on your waist.
- The machine stained with threading oil is slippery. Do not drop the machine on your feet while lifting it.
- Do not install the machine inclined or on an unstable place. The machine falls down, causing injury.
- Keep proper footing and balance at all times. You may tumble and get hurt.
- Do not operate the machine when you cannot concentrate on your work, e.g. when you are tired or while under the influence of alcohol, medication or drugs. Otherwise, accident or injury may occur.
- Before turning on the machine, make sure that hand tools used for inspection or adjustment are removed from the machine. Accident or injury may occur if you start the machine with hand tools on it.
- Use only the accessories and attachments given in this manual and our catalogs. A failure to do so will lead to accident or injury.
- Die-Head is wet and slippery with threading oil. Do not drop it on your feet while replacing.
- Immediately stop the machine if something is wrong with the machine or you have noticed unusual smell, vibration, sound, etc. during operation, and refer to "6. TROUBLE SHOOTING" in this manual and follow the corresponding instructions.
- Repair should only be carried out by our sales representative. Otherwise the machine may not show its performance or you may get injured. Ask the shop of your purchase or our sales office.
- Our products are in accordance with the relevant safety rules. Do not modify them.

# ***BOLT MACHINE 25Pro***

## **⚠ CAUTION**

### **Electric Shock**



- Do not put the machine or workpiece on Power Cord. Damaged cord and current leakage will occur.

### **Falling**



- Do not leave the machine with a long workpiece set on it. You may tumble over it and get hurt.

### **Instruction Manual**



- Securely install accessories in accordance with this manual. Otherwise, accident or injury result.

### **Other**



- Before further use of the machine, a guard or other part that is damaged should be carefully checked to determine that it will operate properly and perform its intended function.
- When the machine is carried with threading oil in it, the oil may splash and stain clothing due to vibration.
- If you have dropped or hit the machine accidentally, carefully check for damage, crack or deformation. If the machine is used with such defect, poor threading accuracy, accident and injury can result.
- Before leaving the machine for a long time, disconnect Power Plug.
- Work wet with threading oil is slippery. Do not drop it on your feet.
- It is mandatory to use Pipe Support for long and heavy workpiece.

## CAUTION

### Other



- **For proper threading, observe the following.**
  - Use the Die-Head and Dies which match the thread size.
  - Install the Die-Head on the Spindle Case properly.
  - Do not put Die-Head direct on the ground and handle it carefully.
  - Make sure that the threading oil pours on the Dies.
  - Avoid deformation and oblique cutting of pipes.
- **Keep your work bench and area tidy and well lit. Cluttered areas and benches invite injuries.**
- **Do not let visitors touch the machine and Power Cord or operate the machine.**
- **When not in use, machines should be stored in dry and high or locked-up place - out of reach of children.**
- **Threading Oil**
  - Threading oil contacting the skin may cause inflammation. Wear protective gloves when handling the threading oil. In case it contacts your hands, completely wash it off with water and soap.
  - Do not drink the threading oil because it causes diarrhea and vomiting. If swallowed accidentally, do not force to vomit and consult a doctor immediately.
  - Keep the threading oil out of reach of children.
  - Do not dilute the threading oil nor mix with other threading oil.
  - When the threading oil is extremely deteriorated causing poorly finished threads, early stage replacement with new oil is recommended.
  - Avoid direct sunlight and store in a dark place. After use, close up the container tightly to prevent dirt and water from entering.



- Do not inhale oil mist or vapor of the threading oil. It causes nausea. If inhaled accidentally, move to a place where fresh air prevails, cover the body to keep warm, lie quietly and consult a doctor.

### Explosion



- Dispose of waste oil and waste oil container as industrial waste. Do not heat the waste container, do not drill holes into it and do not cut it. Ignition or explosion may take place.

# **BOLT MACHINE 25Pro**

---

## **CONTENTS**

1.	OVERVIEW	8
2.	COMPONENTS OF THE MACHINE	
1)	Main Parts	
1-1)	Threading Machine	8
1-2)	Die-Head	8
2)	Specifications	9
3)	Standard Accessories Specification	9
4)	Optional Accessories	9
3.	INSTALLATION	
1)	Carrying the Machine	10
2)	Installation	11
4.	OPERATION	12
1)	Preparing for Operation	
1-1)	Checking Threading Oil	12
2)	Changing Thread Size	
2-1)	Removing and Installing Dies	13
2-2)	Removing and Installing Die-Head	14
2-3)	Changing Thread Size	15
3)	Setting the Workpiece	15
4)	Screw-Cutting Dimensional Setting	15
5)	Threading	16
5-1)	Adjustment of Thread Depth	16
6)	Removing the Workpiece	17
7)	Cleaning after Use	17
5.	MAINTENANCE & INSPECTION	
1)	Replacement of Parts	
1-1)	Replacement of Switch	17
1-2)	Replacement of Pump	18
1-3)	Replacement of Vise-Jaw	19
1-4)	Replacement of Carbon Brush	20
2)	Daily Inspection and Maintenance	21
6.	Before asking for Repairs	22
7.	ELECTRICAL WIRING DIAGRAM	22



## 1. OVERVIEW

- The bolt threading machine, model BOLT MACHINE 25Pro, is intended to rotate a Die-Head for threading. The machine consists of a motor which rotates a die-head, vise to hold workpiece, and a pump to lubricate the threading oil.

## 2. COMPONENTS OF THE MACHINE

### 1) Main Parts

#### 1-1) Threading Machine

- The diagram illustrates main parts and Die-Head of this machine. Workpiece is chucked by Vise and threaded by Die-Head.

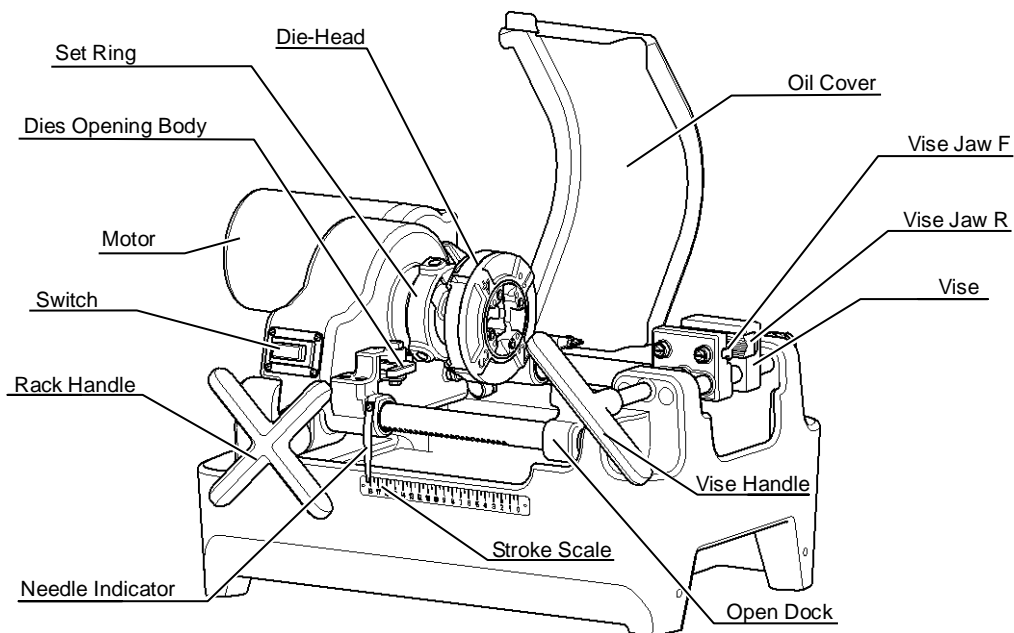

#### 1-2) Die-Head

- The diagram illustrates main parts of Die-Head. Before changing the thread size, change Die-Head and Dies.

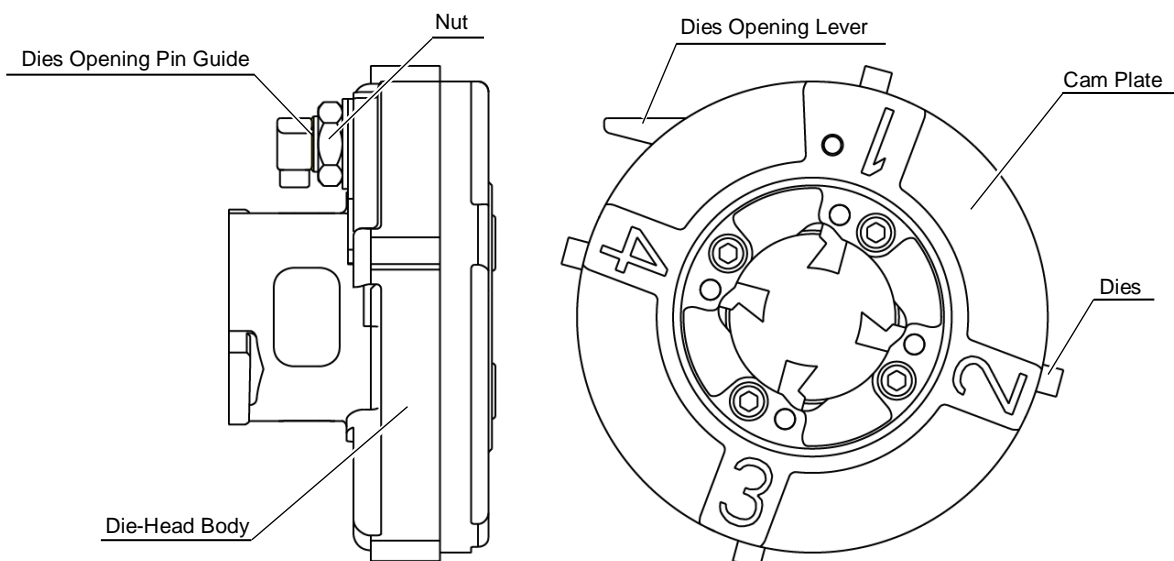

# BOLT MACHINE 25Pro

## 2) Specifications

<b>Cutting capability</b>	BSW(R):5/16"-1", Metric(R):8-24mm
<b>Speed</b>	80min <sup>-1</sup> (rpm) No load
<b>Motor</b>	Single phase Universal Motor,1140W
<b>Frequency</b>	50/60Hz
<b>Weight</b>	45k g
<b>Dimensions</b>	600 × 450 × 380mm (L) X (W) X (H)

\* Specifications are subject to change without prior notice.

\* Voltage made to order.

## 3) Standard Accessories Specification

Specification	BOLT MACHINE 25 Pro	
Die-Head	BSW(R) 5/16"-1"	Metric(R)8-24mm
Dies	BSW(R) 1/2" & 5/8"	Metric(R) 12mm & 14-16mm
Other	4L Threading oil, Set Lever, Instruction manual Hex Wrench, Open-End Wrench, Legs	

## 4) Optional Accessories



Threading Oil 16L

## 3. INSTALLATION

### 1) Carrying the Machine

#### WARNING



- Fix Spindle Case to avoid moving while carrying the machine, hold and lift the bottom of the machine.
- When lifting it, bend your knees to avoid a load on your waist.
- The machine stained with threading oil is slippery. Do not drop the machine on your feet when lifting it.

#### CAUTION



- When the machine is carried with threading oil in it, the oil may splash and stain clothing due to vibration.

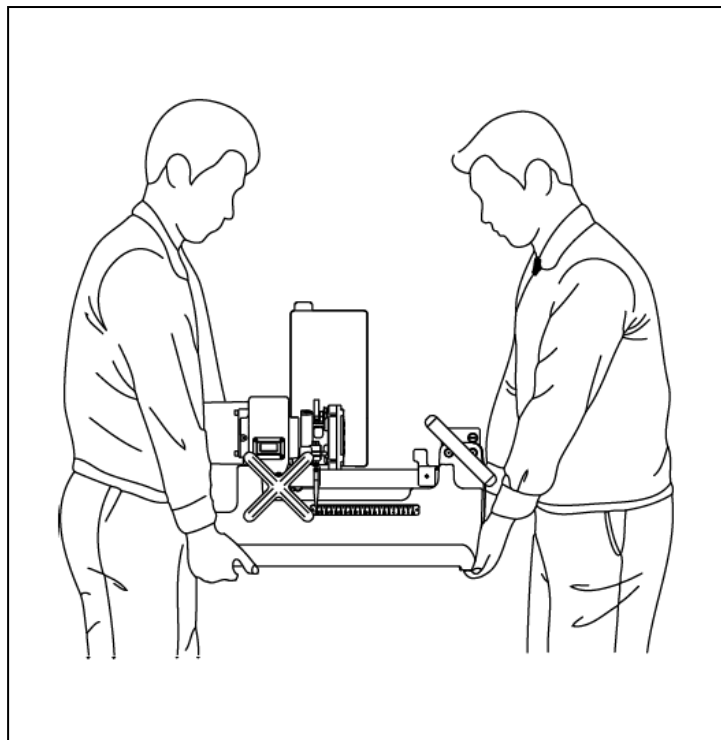

⟨1⟩

# BOLT MACHINE 25Pro

## 2) Installation

### ⚠ WARNING



- Always ground the machine to avoid electric shock and resultant death.



- An extension cord used should be a three-core cable having an earth wire. Use a thick and durable cable for outdoor application.
- Never install an earth on the gas pipe. Explosion may take place.

### ⚠ CAUTION



- Do not put the machine with Vise side higher than other parts.
- Do not use the machine in rain or outdoors. Die-Head or Dies will rust.

- (1) Put the machine in a place free from moisture.
- (2) Put the machine on a flat surface without play or on a flat work bench. In this condition, the Motor side is higher than other parts. (fig.2)
- (3) Secure a sufficient space around the machine. A wide space is necessary particularly when working long and heavy workpiece.
- (4) It is mandatory to use Pipe Support for long and heavy workpiece. Avoid excessive force applied to the machine which causes it to tilt.
- (5) Make sure that the power source is equipped with a ground fault circuit breaker to avoid electric shock.
- (6) Use an earth clip when a power receptacle without a base for grounding is used.
- (7) When an extension cord is used, use the one conforming to the applicable regulations.

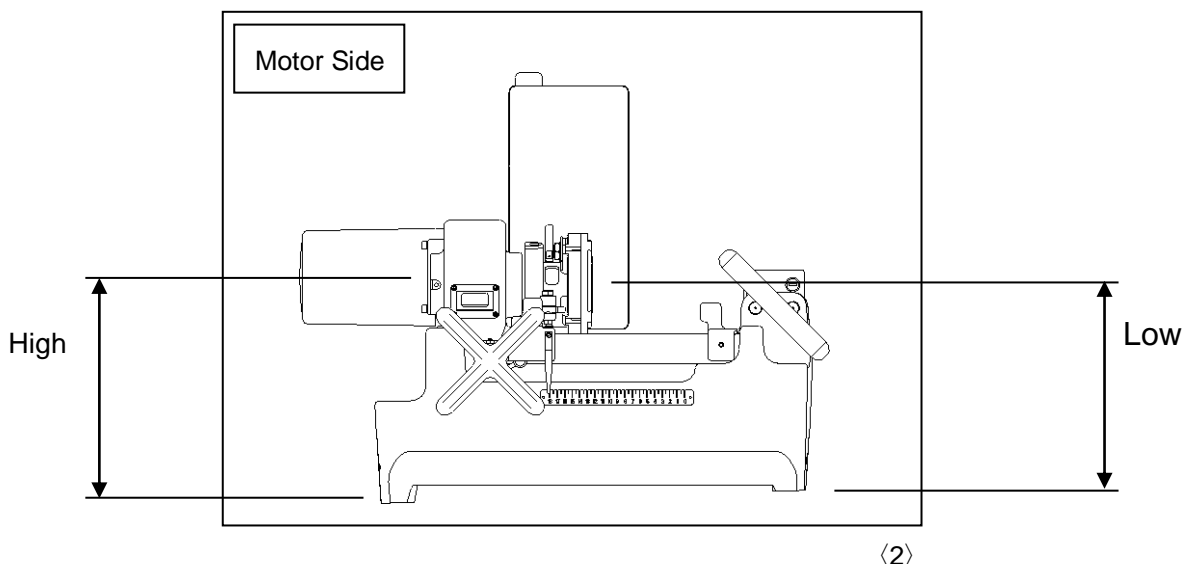

## 4. OPERATION

- The following gives a general description of threading work.
  - (1) Prepare for operation. Check threading oil.
  - (2) Change the size of the thread as required.
  - (3) Install the workpiece on this machine.
  - (4) Thread the workpiece.
  - (5) Remove the threaded workpiece.

The following describes the contents of the above procedures.

### 1) Preparing for Operation

#### 1-1) Checking Threading Oil

- A new machine or a machine not used for a long period of time is coated with rust preventive oil. Wipe it off with a piece of clean cloth.
  - (1) Turn Rack Handle clockwise to move Spindle Case to the left side.
  - (2) Fill the provided threading oil from the right side of the machine. ( fig.3)

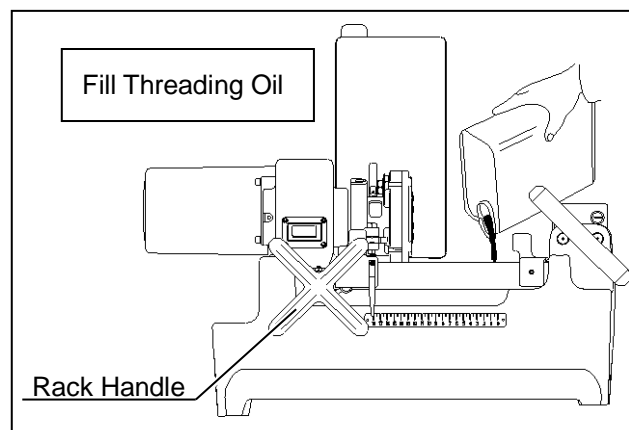

⟨3⟩

- (3) Make sure the machine is switched off and plug Power Plug into receptacle. A two-core receptacle must always be grounded.
- (4) Switch on the machine and make sure the threading oil flows from Oiling Pipe.
- (5) Oil Tank capacity is 10L.  
For heavy use, recommend to add more oil than standard (4L) for much efficient cooling.

# BOLT MACHINE 25Pro

## 2) Changing Thread Size

### 2-1) Removing and Installing Dies

[Removal]

**CAUTION**



·Wear gloves to avoid cutting hands by the Dies.

- (1) Use open-end wrench provided and loosen (leftward) Nut on back of Die-Head, then slide Cam Plate by pushing Dies Opening Lever toward (A) direction along by the groove on the Die-Head Body. (fig4)
- (2) Open Dies Opening Lever to the end to (A) direction.
- (3) Pull Dies to remove.

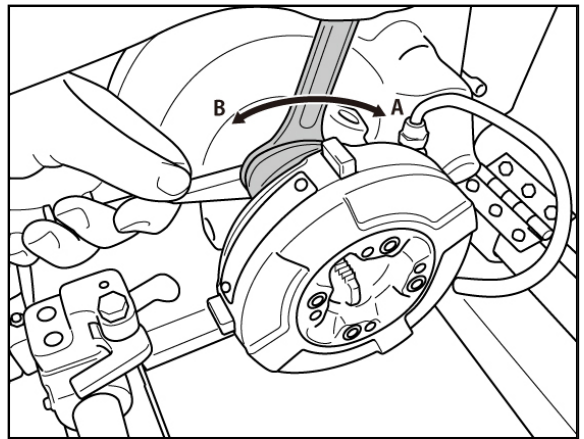

〈4〉

[Installation]

**CAUTION**



·Proper threading cannot be achieved unless the number on the Die-Head slot matches that on the Dies.

- (1) Use Open-End Wrench provided and loosen (leftward) Nut on back of Die-Head, then slide Cam Plate by pushing Dies Opening Lever toward (A) direction along by the groove on the Die-Head Body. (fig4)
- (2) Open Dies Opening Lever to the end to (A) direction.
- (3) Insert Dies into the Die-Head slots. The number showing on the Dies and Die-Head slot must be same. (1-4) Inserting Dies to the slot, a click sound will be occurred. That is the right position of the Dies. (If numbers on the Dies and the slots are unmatched, cannot produce proper threads.) Dies should be inserted to Die-Head with the side which showing number at spindle side. (fig5,6)
- (4) Close Dies Opening Lever to the end to (B) direction. (fig.4)
- (5) Slide Cam Plate by pulling Dies Opening Lever toward (B) direction along by the groove on the Die-Head Body.
- (6) Close Nut.

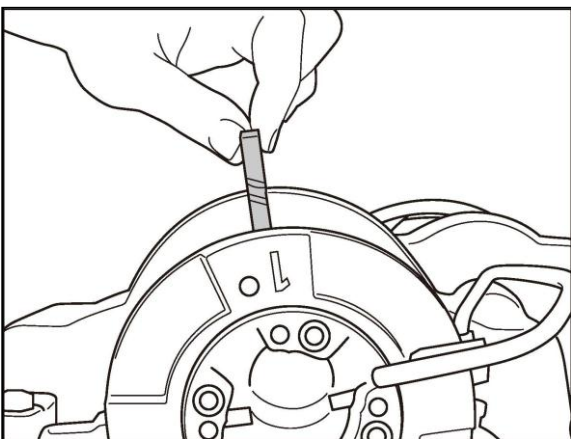

〈5〉

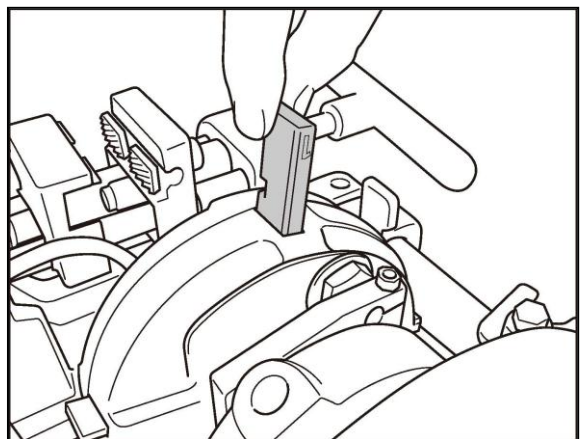

〈6〉

## 2-2) Removing and Installing Die-Head

### ⚠ CAUTION



- When remove Die-Head, hold it by hand not to fall down.
- Die-Head will be removable once Set Ring released.

### [Removing Die-Head]

- (1) Set gaps on Spindle and Set Ring at same position. (fig.7)
- (2) Fit together holes on Die-Head and Spindle Pin, Make sure Spindle and Die-Head joints fit perfectly. (fig.8) (Fitting surface must be cleaned without cutting tips or other foreign bodys.)
- (3) Slide Set Ring by hand and fix Die-Head.
- (4) Insert Set Lever to the hole on Set Ring and make impacts a few times toward (A) direction by hand to tighten. (fig.9)
- (5) To remove, apply pressure on Set Lever to (B) direction.

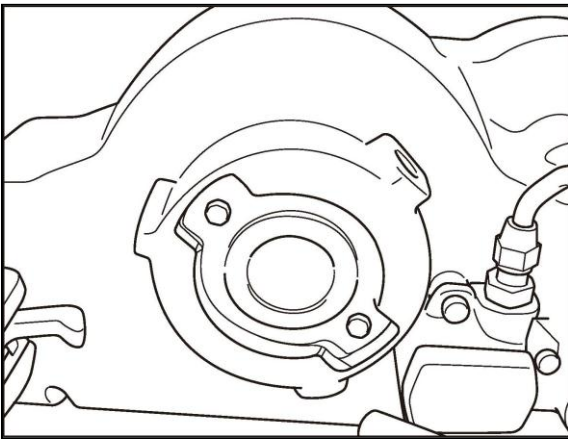

⟨7⟩

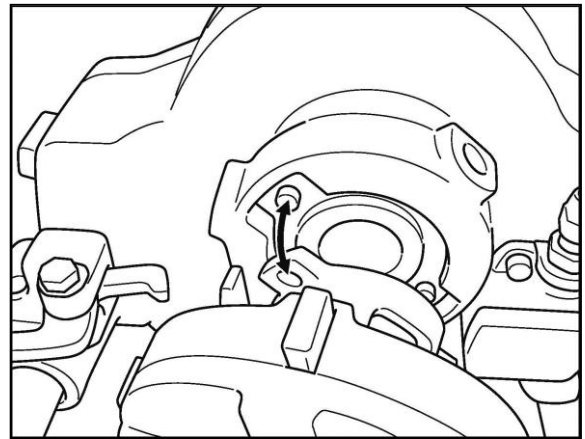

⟨8⟩

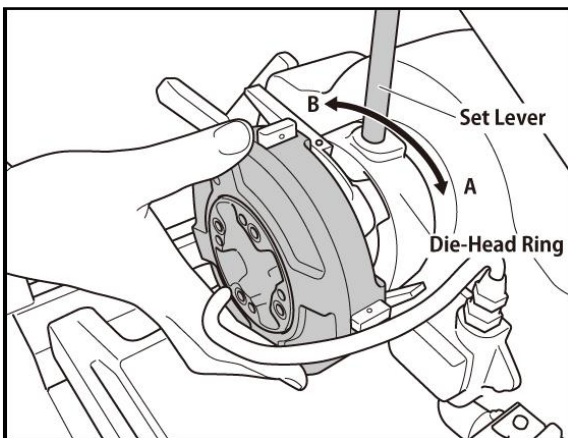

⟨9⟩

# BOLT MACHINE 25Pro

## 2-3) Changing Thread Size

- (1) Loosen Nut.
- (2) Close Dies Opening Lever to the end to (B) direction. (fig.4)
- (3) Slide Cam Plate by moving Dies Opening Lever along by the groove on the Die-Head Body and aligning with indicator for the proper screw-cutting position.
- (4) Close Nut so as to prevent slipping out of this position.

## 3) Setting the Workpiece

- (1) Turn Vise Handle to left, opening jaws slightly more than size of workpiece outside diameter.
- (2) Hold workpiece with one hand and use the other to turn Vise Handle in order to grip it lightly.
- (3) Then use both hands to turn Vise Handle.

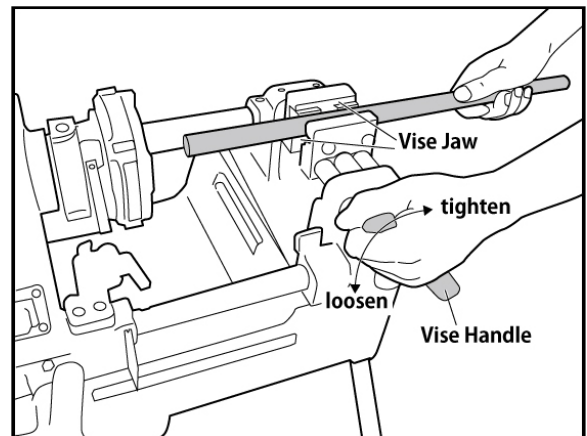

<10>

## 4) Screw-Cutting Dimensional Setting

- (1) Align Needle Indicator on Spindle Case with Stroke Scale position. (fig11)
- (2) Bring workpiece in contact with Dies, then close the Vise.
- (3) Cutting can be done at the dimension thus obtained.
- (4) Screw-cutting of a long workpiece can be done by repeating the following procedure, cut switch before Die-Head releases workpiece automatically, open the Vise a bit and reposition workpiece; Turn the switch on again and proceed.

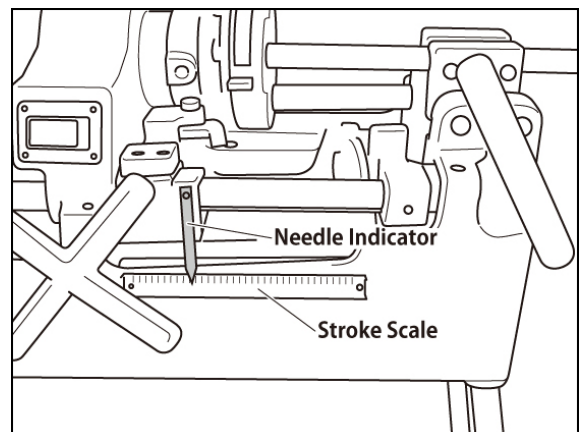

<11>



## 5) Threading

- (1) Close Dies Opening Lever to the end to (B) direction. (fig.4)
- (2) Turn the switch ON, turn the Rack Handle counterclockwise. (fig12)
- (3) Take hands off from the Rack Handle after two or three threads were cut.
- (4) Dies are opened automatically when threading done. Switch off when the threading is completed.

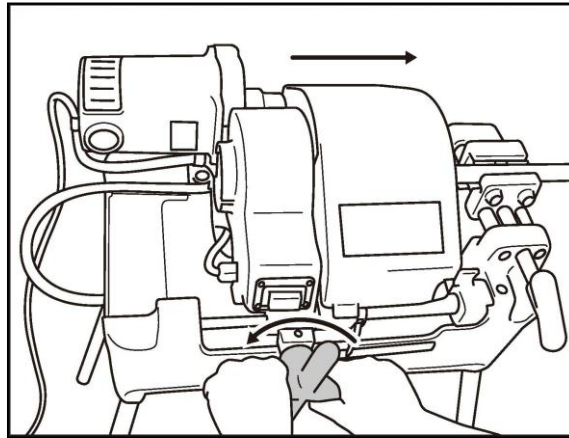

〈12〉

### 5-1) Adjustment of Thread Depth

- (1) Close Dies Opening Lever to the end to (B) direction. (fig.4)
- (2) Loosen Nut of Die-Head.
- (3) Slide Cam Plate by moving Dies Opening Lever along by the groove on the Die-Head Body.  
Slide the marker on Cam-Plate upward to get shallower and downward to get deeper threads.  
(fig.13)
- (4) Close Nut so as to prevent slipping out of this position.

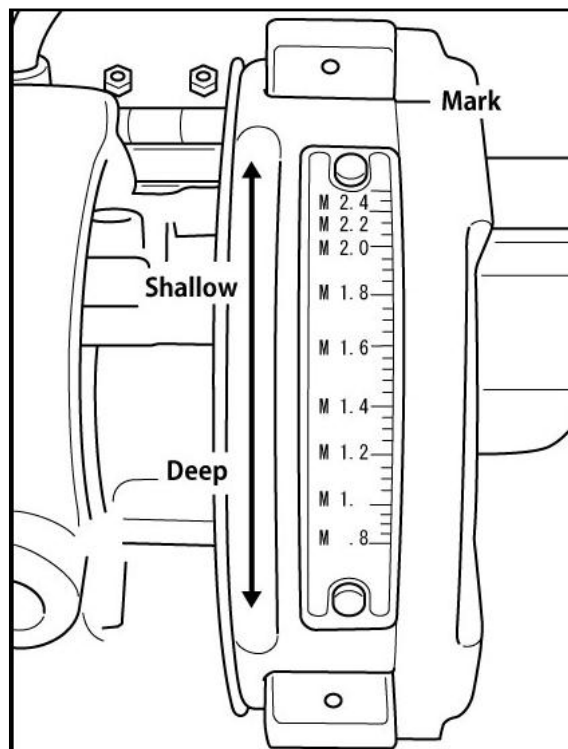

〈13〉

# BOLT MACHINE 25Pro

## 6) Removing the Workpiece

### ⚠ CAUTION



- The workpiece is wet and slippery with threading oil. Use utmost care not to drop on your feet.

- (1) Turn Rack Handle clockwise and return Spindle Case.
- (2) Loosen Vise and pull out the workpiece.

## 7) Cleaning after Use

### ⚠ CAUTION



- Do not blow off chips using air. They may get into eyes and loss of eyesight may result.



- Chips are sharp. Do not touch them with bare hand. Always wear gloves.

- Remove chips scattered on the machine or in the area.
- Use a wire brush and clean and remove chips from Dies of Die-Head and Vise-Jaw.
- Use waste cloth and wipe off the threading oil splashed over the machine and the area.

## 5. MAINTENANCE & INSPECTION

### 1) Replacement of Parts

#### 1-1) Replacement of Switch

### ⚠ WARNING



- Disconnect Power Plug to avoid electric shock.

- (1) Remove the four screws, and pull out Switch Plate on the front.
- (2) Remove the four lead wires from the switch.
- (3) Remove the switch from Switch Plate.
- (4) Install a new switch on Switch Plate.
- (5) Install the four lead wires to the switch.
- (6) Install Switch Plate into the machine with the four screws.

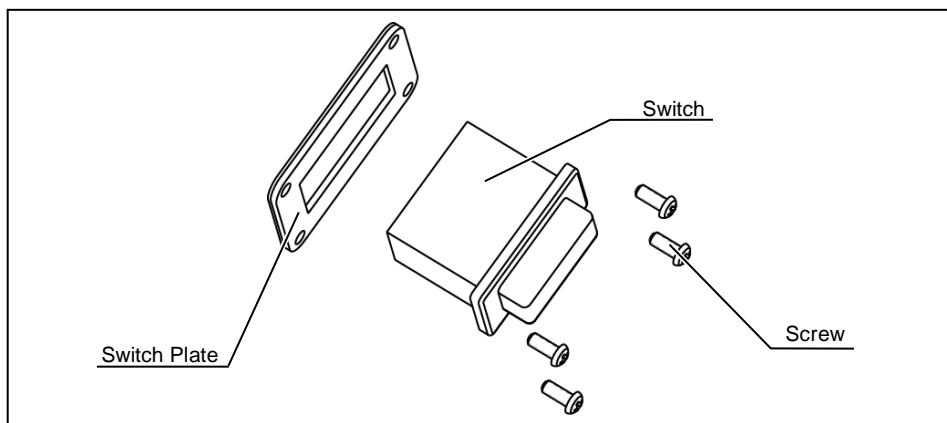

<14>

## 1-2) Replacement of Pump

(1) Turn the pump mounting bolts and remove Pump from this machine. (fig15)

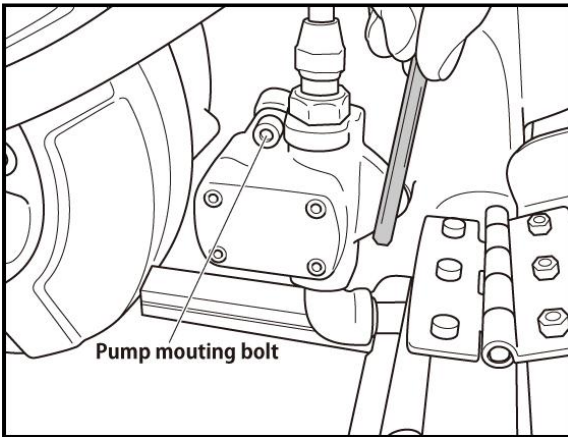

〈15〉

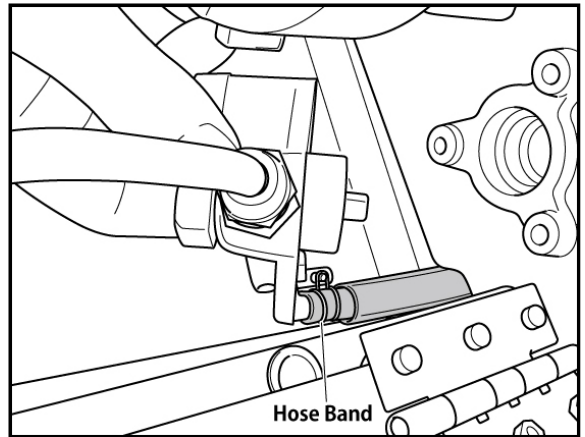

〈16〉

(2) Loosen the hose band and remove the hose from Pump. Pay attention to the overflowing oil.

(3) Install a new Pump and firmly tighten the hose band. (fig16)

(4) Turn Pump Shaft, set it to the groove on the machine side and install Pump with the removed bolts. (fig.17)

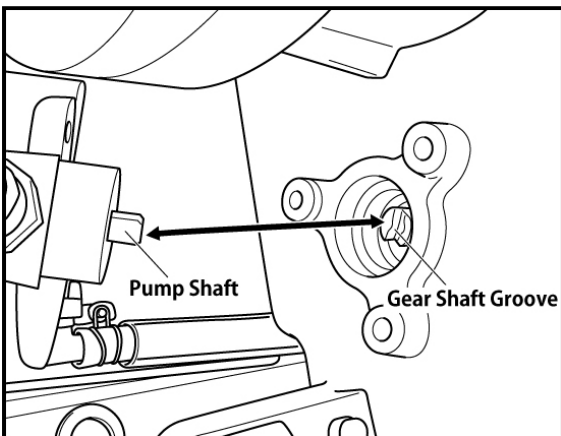

〈17〉

(5) Turn ON the switch and ensure the oil flows out from Oiling Pipe.

# BOLT MACHINE 25Pro

## 1-1) Replacement of Vise-Jaw

### ⚠ CAUTION



• Disconnect Power Plug before work.

- (1) Turn Rack Handle clockwise so that Spindle Case moves to the left side.
- (2) Turn Vise Handle and open Vise.
- (3) Loosen the screws securing Vise-Jaw F. (fig18)

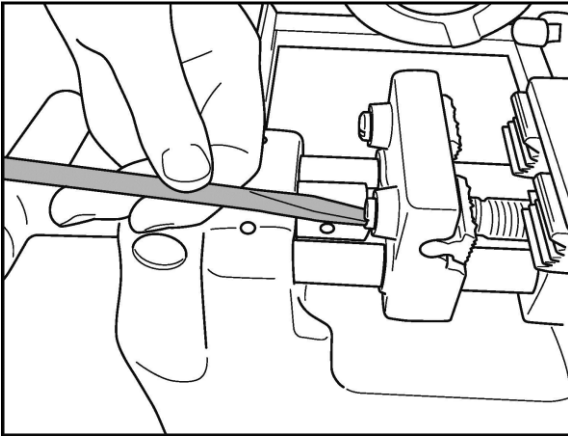

<18>

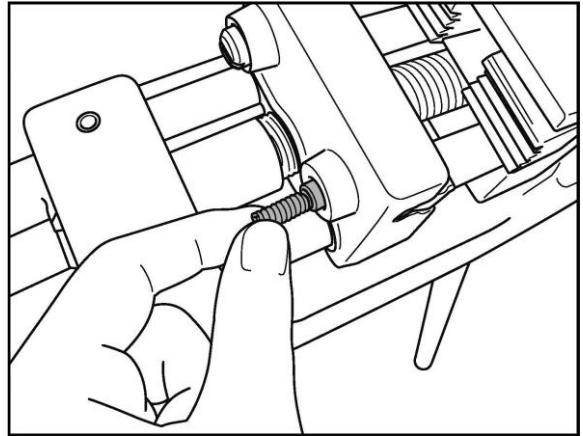

<19>

- (4) Pull out springs (2pcs) and Chuck Pin from the screw holes. (fig19)
- (5) Pull Vise-Jaw F forward. Vise-Jaw F must be replaced both two pieces at the same time. (fig20)
- (6) Remove cutting chips, dusts and oils from Vise Jaw F.
- (7) Insert new Vise Jaw F to the end and tighten screws after insert springs (2pcs) and Chuck Pin.

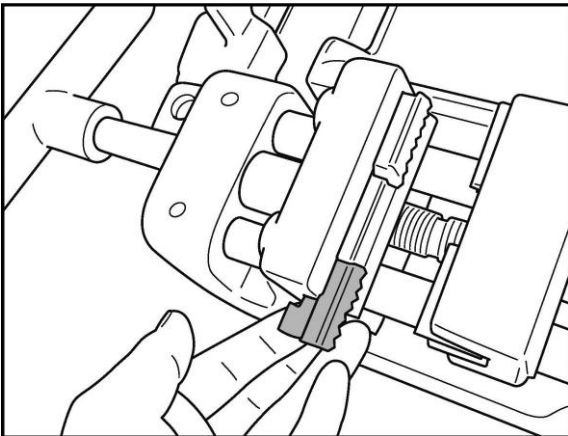

<20>

(8) Loosen the screws securing Vise-Jaw R. (fig21)

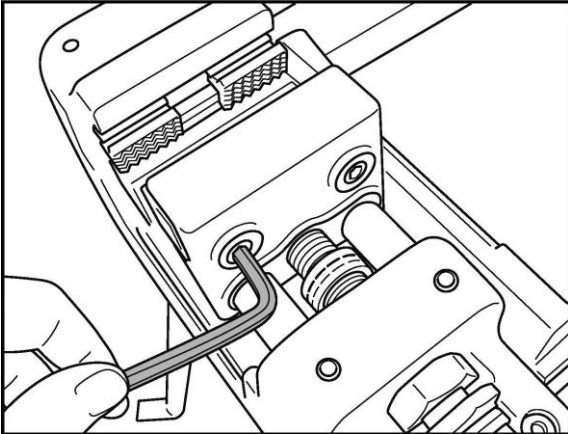

(21)

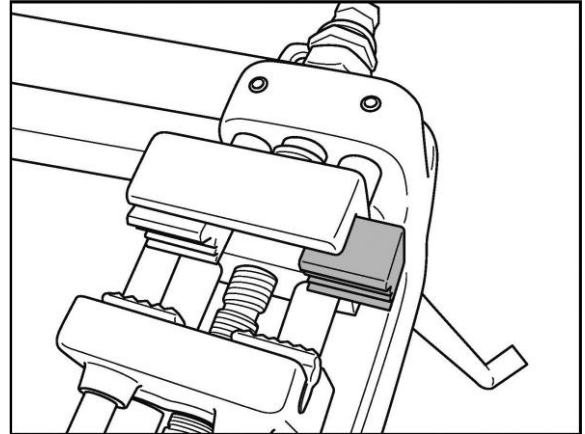

(22)

(9) Pull Vise-Jaw R forward. Vise-Jaw R must be replaced both two pieces at the same time. (fig22)

(10) Remove cutting chips, dusts and oils from Vise Jaw R.

(11) Insert new Vise Jaw R to the end and tighten screws.

## 1-4) Replacement of Carbon Brush

### ⚠ WARNING



• Disconnect the Power Plug to avoid electric shock.

### ⚠ CAUTION



• Keep the new carbon brush free from oil, dirt, chips, etc. Avoid stain of gloves from attaching to the Carbon Brush.

(1) Turn the cap inside with a flat screwdriver and take out the Carbon Brush. (fig23)

(2) Insert a new Carbon Brush. Do not stain the Carbon Brush with oil on fingers, etc. (fig24)

(3) Install the cap.

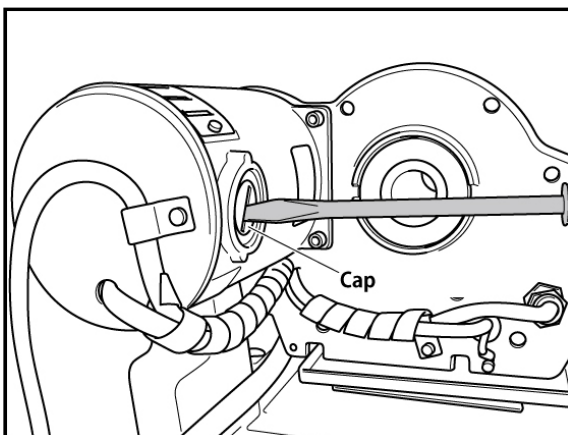

(23)

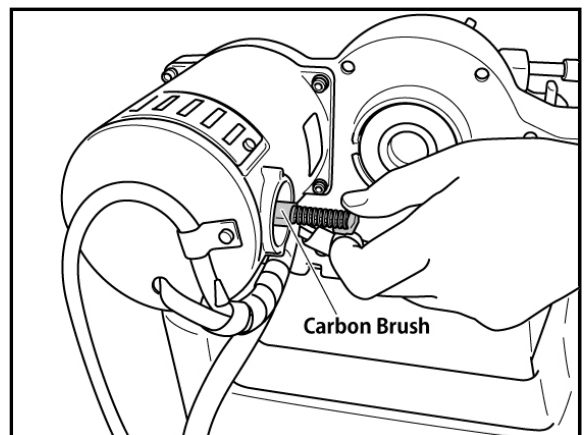

(24)

# BOLT MACHINE 25Pro

## 2) Daily Inspection and Maintenance

### ⚠ CAUTION



• Do not wet the motor with water or oil.

- \* Immediately replace Power Plug, Power Cord and extension cord, if damage.
- \* Ensure the oil is filled up to the tank lid wire netting. If not, replenish.

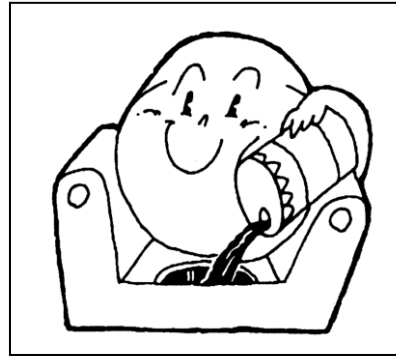
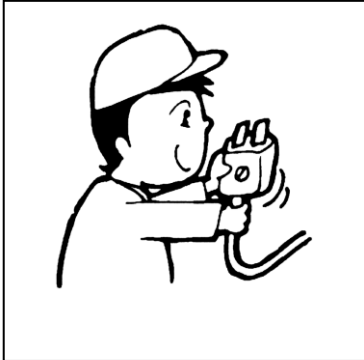

- \* Contamination in the tank causes pump failure. Clean the tank on a periodic basis.
- \* Check Dies for chipping. Replace if chipped.

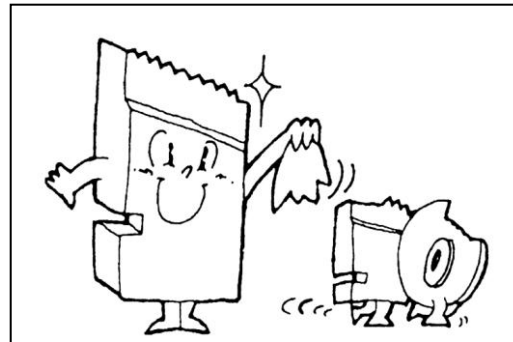
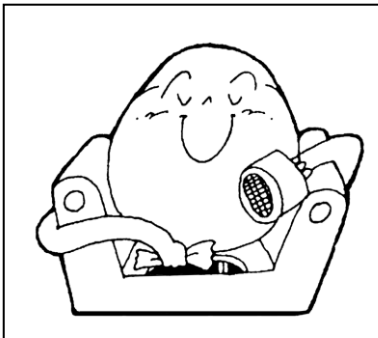

- \* Clogged Vise-Jaws cause improper chucking. Clean with wire brush.

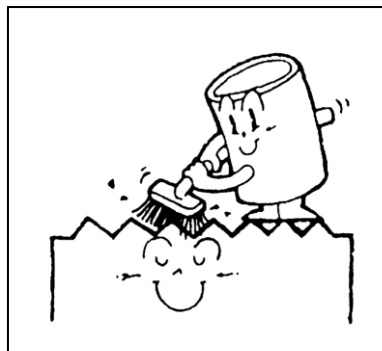

- \* Check for loose fitting screws of parts. If used loosened, danger can result. Retighten them.
- \* Completely wipe off dirt and chips from the machine.
- \* Coat the machine with rust preventive grease when the machine is not used for a long period of time.

## 6. Before asking for Repairs

### 1) In case the oil does not come out:

- \* Is Oil Tank full of oil ?
- \* Are Suction Pipe, Tank Lid wire netting and Filter clear ?
- \* Is Pump in order ?

### 2) In case power is not enough:

- \* Has the power voltage not dropped ?
- \* Is the extension cord not too long or slim ?

### 3) In case threads are not normal:

- \* Is the threading oil not contaminated or dirty ?
- \* Are there chipping of Dies ?
- \* Is the cut end or the workpiece not oblique ?

### 4) In case threading fails:

- \* Is the dies size correct ?
- \* Do Die numbers agree with those on Die-Head ?
- \* Is the size selection of Die-Head correct ?

### 5) In case workpiece slips during cutting:

- \* Vise Jaws worn.
- \* Grooved portion of Vise Jaws is clogged with chips.
- \* Workpiece not gripped tightly enough.

### 6) In case Dies not slide to open/close:

- \* Cutting chips are existing inside Die-Head.
- \* Broken Dies Opening Pin.
- \* Forgot to tighten a nut on Dies Opening Lever.

## 7. ELECTRICAL WIRING DIAGRAM

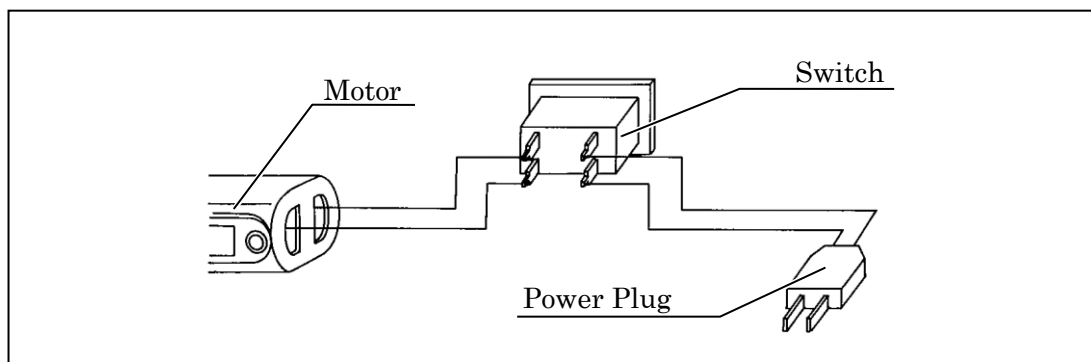

## ●CUSTOMER NOTE

Please enter the following use. This note will be useful  
In making inquiries and placing purchase orders for parts

**SERIAL No. :**

**DATE OF PURCHASE :**

**SALES REPRESENTATIVE :**

**Asada**  
**ASADA CORPORATION**

3-60, Kamiida, Nishi-Machi, Kita-Ku, Nagoya, Japan 462-8551

TEL +81-52-914-1062

FAX +81-52-914-1065

URL <http://www.asada.co.jp>

E-mail: [trade@asada.co.jp](mailto:trade@asada.co.jp)