

# Asada

## Band Saw **BEAVER8·8F**

### INSTRUCTION MANUAL

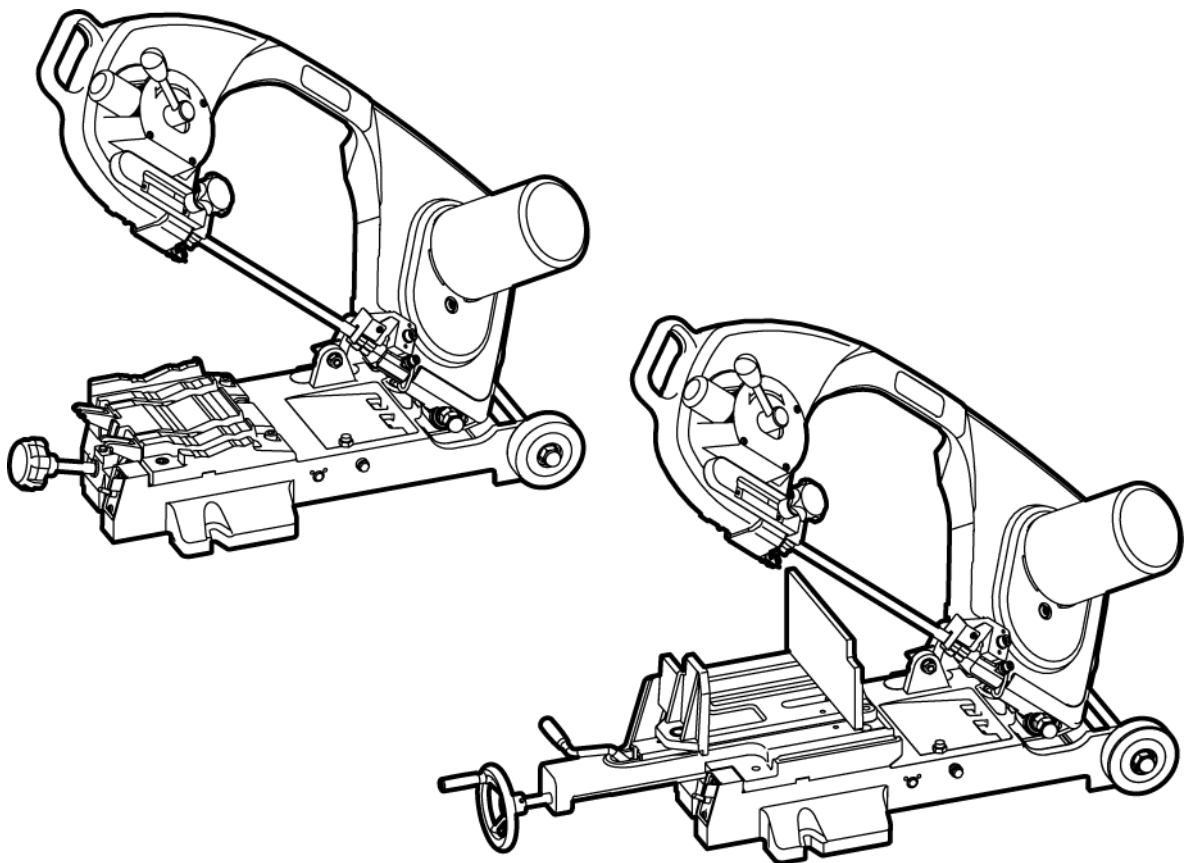

[Read through this manual carefully before using the machine]

# BEAVER 8·8F

## SAFETY PRECAUTIONS

Thank you for choosing our Band Saw Beaver 8 / 8F.

\*This Instruction Manual must be retained by the user of this machine.

\*Read this Instruction Manual carefully and completely before use and thoroughly understand the usage, capacity, cautions, and easy repairs for correct operation.

\*Handle the machine properly to make full use of its functions for safe work.

\*After reading the instructions, save this manual so that you can read it when necessary.

\*Use the machine for the intended application only. It will do a better job and be safer at the rate for which it was designed.

\*Upon receiving the machine, check the following.

- Check that the machine is built conforming to the specifications stated in your order.
- Check the overall machine for any damage or deformation caused in transit due to accidents or other reasons.
- Check that all items and accessories delivered.

In case any discrepancy is found, immediately report the fact to the shop you purchased or our sale office.

(The contents of this manual are subject to change without prior notice.)

## CLASSIFICATION OF CAUTIONS

Precautionary signs are classified into the following 3 levels



**DANGER** Indicates an imminently hazardous situation which, if not avoided, will result in death or serious injury.



**WARNING** Indicates a potentially hazardous situation which, if not avoided, could result in death or serious injury.



**CAUTION** Indicates a potentially hazardous situation which, if not avoided, may result in minor or moderate injury. It may also be used to alert against unsafe practices.

## SYMBOLS



Electric Shock



Cutting Blade



Dragging



Pinching

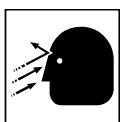

Splashing

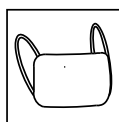

Mask



Explosion



Fire



High Temperature



Falling

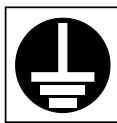

Earth



Rotation parts



Other

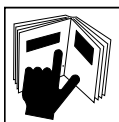

Instruction manual

## OPERATING INSTRUCTIONS

### DANGER



- Always ground the machine to avoid electric shock or resultant death.
- Do not touch the plug with wet hands.
- Do not expose the machine to rain and water and do not use it in damp or wet locations. Humidity will deteriorate motor insulation or lead to electric shock.



- Immediately replace Power Plug, Power Cord or extension cord, if damaged.
- Do not hold the Power Cord and pull it to disconnect from the receptacle and do not put the machine on the cord and damage it.
- An extension cord used should be a three-core cable having an earth wire. Use a thick and durable cord for outdoor use.

### WARNING



- Always use the machine at the voltage indicated on Machine Plate. Otherwise, the machine may become hot, emit smoke or catch fire.
- At cutting do not force the machine in a manner that the motor stops due to an overload switch.
- Immediately replace the Power Plug, Power Cord and extension cord, if damaged.
- If the machine has emitted smoke or took fire, do not disassemble it but have it inspected or repaired by a qualified person.



- Never install an earth wire to the gas pipe. If attempted, explosion may take place.
- Do not use the machine in the presence of flammable liquids or gases such as gasoline and thinner. Otherwise, ignition or explosion may take place.



- The machine and other parts coast for a while after the switch is turned off. Never touch them while they are moving.
- Cut surfaces are very sharp and do not touch them with your hands.
- When it is required to touch the saw blade and moving parts for replacement, etc., switch off the machine and unplug it before starting that operation.

# BEAVER 8·8F

## WARNING



-Before plugging the machine in, always make sure that the switch is OFF. If the machine remains plugged in, it will start suddenly, leading to unexpected accident or injury.



-During operation, keep your hands and face away from the moving parts. You may be caught in the moving parts, causing injury.

-Do not use gloves for works such as cutting. You may be caught in the moving parts, causing injury.

-Do not wear neckties, open-sleeved clothing, knitted gloves, loose clothing or jewelry (such as necklaces). Otherwise, you may get caught in moving parts.

-Wear caps or protective hair covering to contain long hair. Otherwise, you may get caught in moving parts.

-When not in use or when servicing, cleaning, checking or replacing parts, switch off and unplug the machine. If the machine remains plugged in, it will start suddenly, leading to accident or injury.

-Do not leave the machine unattended during rotating. Others may get caught in moving parts.

-It is mandatory to use Pipe Support for long and heavy work to avoid shaking and distortion of the work during turning and tilting of the machine by the weight of the workpiece. Otherwise, the workpiece and the machine become unstable.

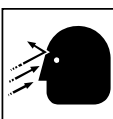

-Wear safety glasses while operating the machine. Chips enter your eyes and nose.

-Do not blow off chips using compressed air. They may get into your eyes and loss of eyesight may result.

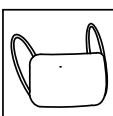

-Use a face or dust mask if operation creates dust. Sawdust and dirt may enter your eyes and nose.



-Immediately after cutting, fragment are hot. Do not touch them directly with hands.



-When lifting the machine, bend your knees to avoid a load on your waist.

-The machine with chip is slippery. Do not drop the machine on your feet while lifting it.

-Do not install the machine inclined or on an unstable place. The machine fall down, causing injury.

## WARNING



- Keep proper footing and balance at all times. You may tumble and get hurt.
- Do not operate the machine when you cannot concentrate on your work, e.g. when you are tired or while under the influence of alcohol, medication or drugs. Otherwise, accident or injury may occur.
- Before turning on the machine, make sure that hand tools used for inspection or adjustment are removed from the machine. Accident or injury may occur if you start the machine with hand tools on it.
- Use only the accessories and attachments given in this manual and our catalogs. A failure to do so will lead to accident or injury.
- Immediately stop the machine if something is wrong with the machine or you have noticed unusual smell, vibration, sound, etc. during operation, and refer to "5.TROUBLE SHOOTING" in this manual and follow the corresponding instructions.
- Repair should only be carried out by our sales representative. Otherwise the machine may not show its performance or you may get injured. Ask the shop of your purchase or our sales office.
- Our products are in accordance with the relevant safety rules. Do not modify them.

## CAUTION



-Do not put the machine or workpiece on the Power Cord. Damaged cord and current leakage will occur.



-Watch the position of your finger while lowering frame to avoid pinching of fingers.  
-Do not leave the machine with a long workpiece set on it. You may tumble and get hurt.



-Securely install accessories in accordance with this manual. Otherwise, accident or injury result.



-Before further use of the machine that is damaged should be carefully checked to determine that it will operate properly and perform its intended function.



-If you have dropped or hit the machine accidentally, carefully check for damage, crack or deformation. If the machine is used with such defect, poor cutting accuracy, accident and injury can result.

-Before leaving the machine for a long time, disconnect the Power Plug.

-The work material with chip is slippery. Do not drop it on your feet.

-Keep your work bench and area tidy and well lit. Cluttered areas and benches invite injuries.

# ***BEAVER 8·8F***

---

## **CAUTION**



- Do not let visitors touch the machine and Power Cord or operate the machine.
- When not in use, machines should be stored in dry and high or locked up place - out of reach of children.

## CONTENTS

1. COMPONENTS OF THE MACHINE	
1) Main Parts-----	7
2) Specifications-----	9
3) Optional Accessories-----	9
3-1) Saw Blade and Cutting Load Selecting Chart by material -----	11
3-2) Falling time of the Frame by Speed Adjust Knob-----	12
2. INSTALLATION	
1) Carrying the Machine-----	13
2) Transport-----	13
3) Installation-----	13
4) Proper working environment-----	14
3. OPERATION	
1) Replacement the Saw Blade-----	15
2) Adjustment of Blade Guide F -----	16
3) Clamp the material-----	16
4) Adjustment of Cutting speed-----	17
5) Cutting-----	19
6) Removing the Workpiece-----	20
4. MAINTENACE & INSPECTION	
1) Replacement of Parts	
1-1) Replacement the Pulley Rubber-----	21
2) Correction Procedure for Oblique Cutting (Flat Vise type) -----	22
3) Daily Inspection and Maintenance-----	22
5. BEFORE ASKING FOR REPAIRS-----	24
6. ELECTRICAL WIRING DIAGRAM-----	26

# BEAVER 8·8F

## 1. COMPONENTS OF THE MACHINE

### 1) Main Parts

Warning sticker is pasted on this machine. This sticker show how to keep safety, so keep it clean. If it peeled off or it's printing disappeared, please petition our company to send new warning sticker. And affix new one on the same place.

## BAND SAW BEAVER 8

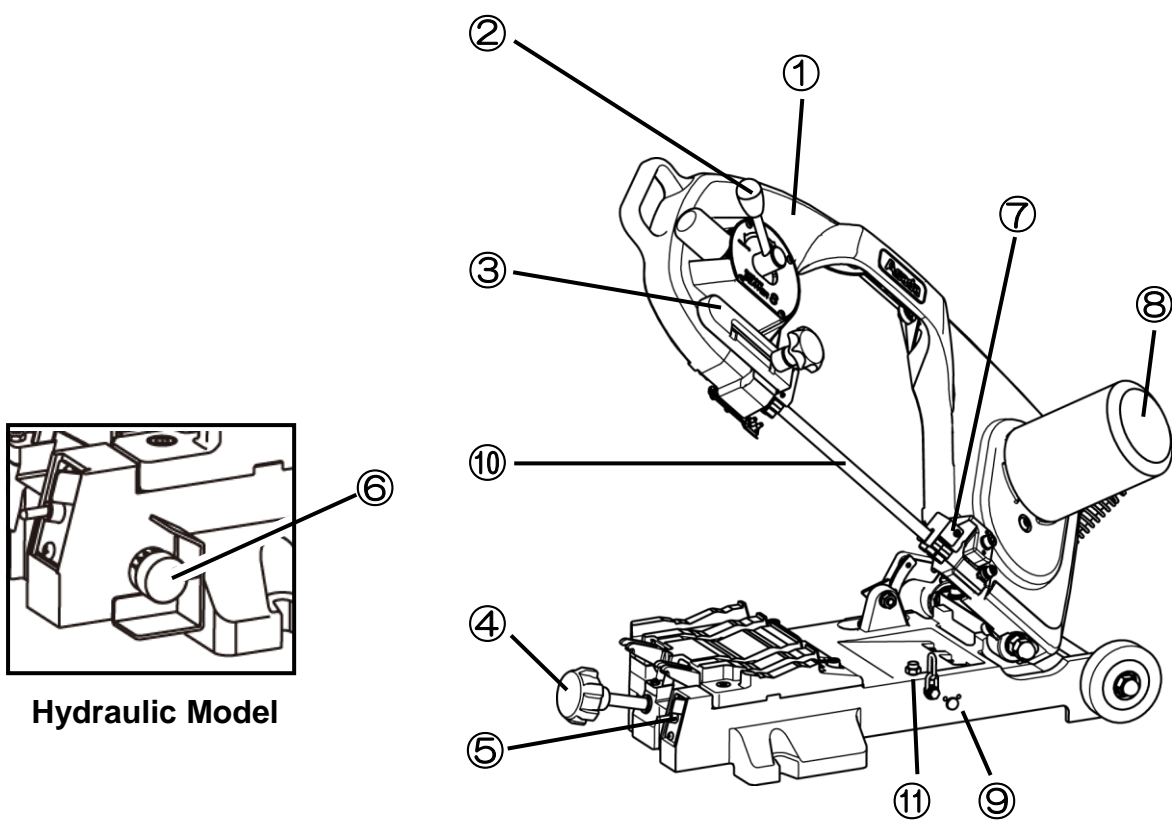

1. Frame	7. Blade Guide R
2. Tension Handle	8. Motor
3. Blade Guide F	9. Overload Protector Reset Button
4. Clamp Handle	10. Saw Blade
5. Power Switch	11. Stop Bolt
6. Speed Adjust Knob	



## BAND SAW BEAVER 8F

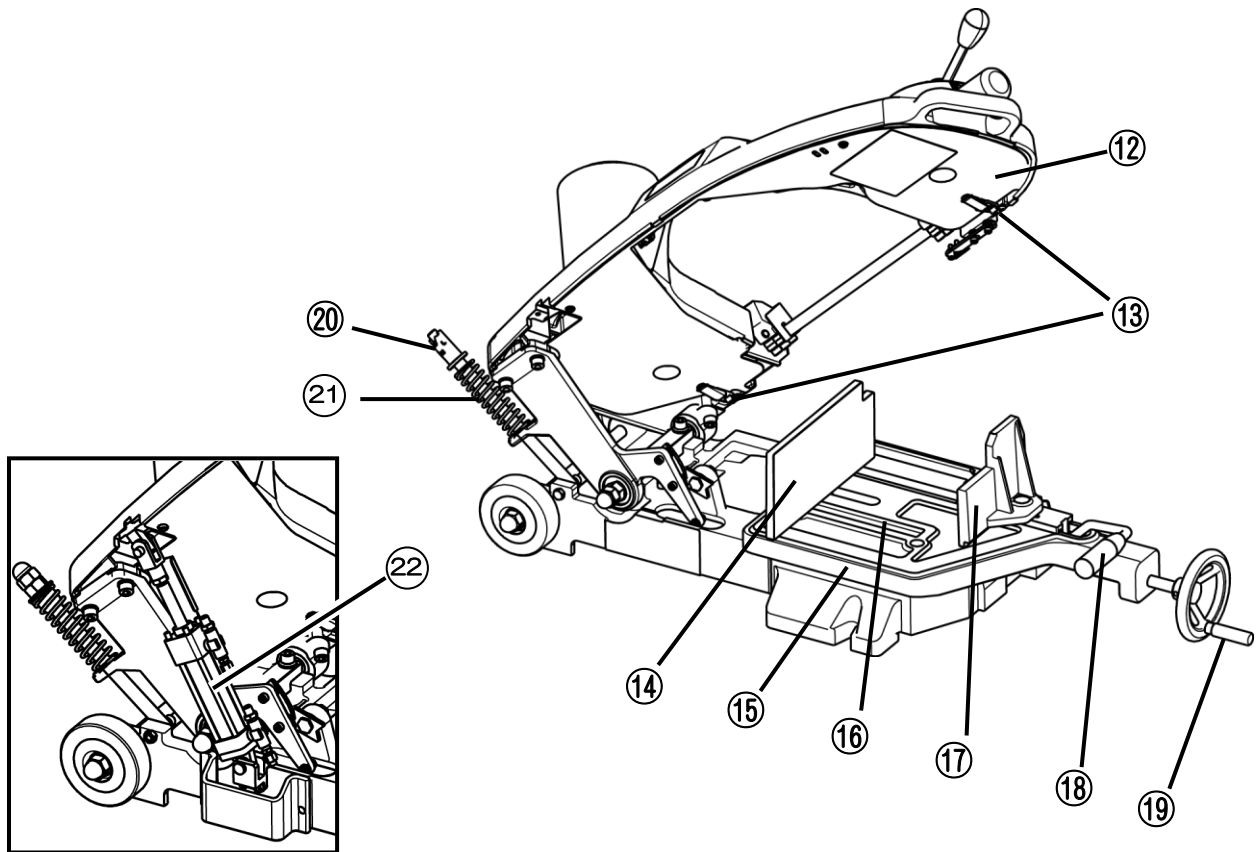

Hydraulic Model

12. Back-Plate	18. Clamp Rod
13. Back-Plate Stopper	19. Clamp Handle
14. Flat Vise R	20. Change-Cap
15. Flat Vise	21. Weight-Adjust Spring
16. Scale Plate	22. Hydraulic cylinder
17. Flat Vise F	Hydraulic oil "VG22"

# BEAVER 8·8F

## Specifications

Item		Band Saw Beaver 8 (Chain Vise)		Band Saw Beaver 8F (Flat Vise)	
Weight-Adjust		Spring	Hydraulic	Spring	Hydraulic
Cutting capability	Round Pipe	φ220		φ220	
	Square Pipe	□175		□175	
	Angle cut	—		φ115	□125
Blade speed		0.72/0.9 m/s (50/60Hz)			
Motor		Condenser motor, Voltage made to order, 50/60Hz,200W			
Dimension (Net) (LxWxH)		1025x390x490 mm		1060x390x490 mm	
Dimension (Gross) (LxWxH)		1200x580x690 mm			
Weight (Net)		52kg	54kg	61kg	63kg
Weight (Gross)		61kg	63kg	70kg	72kg
Standard accessories		70446 Saw blade (14T.P.I Bimetal)		70446 Saw blade (14T.P.I Bimetal) 86512 L Socket Wrench (17)	

\*Specifications are subject to change without prior notice.

### 3) Optional Accessories

Code No.	Description	Pcs	Remarks
70439	Saw blade,8 T.P.I for Band Saw 222 and Beaver 8, 10	10pcs	Steel over t=10mm
70440	Saw blade,10 T.P.I for Band Saw 222 and Beaver 8, 10	10pcs	Steel over t=8mm
70441	Saw blade,14 T.P.I for Band Saw 222 and Beaver 8, 10	10pcs	Galvanized Iron pipe 1/2 / Steel over t=6.1mm
70442	Saw blade,18 T.P.I for Band Saw 222 and Beaver 8, 10	10pcs	Galvanized Iron pipe 1/2 / Steel over t=3.7mm
70443	Saw blade,24 T.P.I for Band Saw 222 and Beaver 8, 10	10pcs	Steel under t=3.6mm / conduit thin wall pipe

# **BEAVER 8·8F**

---

Code No.	Description	Pcs	Remarks
70444	Saw blade,8 T.P.I, bimetal for Band Saw 222 and Beaver 8, 10	5pcs	Steel over t=10mm / Stainless steel pipe over t=7mm
70445	Saw blade,10 T.P.I, bimetal for Band Saw 222 and Beaver 8, 10	5pcs	Steel over t=8mm / Stainless steel pipe over t=7mm
70446	Saw blade,14 T.P.I, bimetal for Band Saw 222 and Beaver 8, 10	5pcs	Galvanized Iron pipe 1/2 / Stainless steel pipe over t=4mm
70493	Saw blade,18 T.P.I, bimetal for Band Saw 222 and Beaver 8, 10	5pcs	Stainless steel pipe under t=4mm / conduit thin wall pipe
70447	Saw blade,24 T.P.I, bimetal for Band Saw 222 and Beaver 8, 10	5pcs	Stainless steel pipe under t=2.1mm / conduit thin wall pipe
BS620	PIPE SUPPORT	1	Max height : 165mm Min height : 105mm Max load : 150kg

# BEAVER 8·8F

## 3-1) Saw Blade and Cutting Load Selecting Chart by material [ Spring Model ]

● : H (Heavy) ◎ : M (Medium) ○ : H (Light)

		8 T.P.I. No.70439	10 T.P.I. No.70440	14 T.P.I. No.70441	18 T.P.I. No.70442	24 T.P.I. No.70443	Bimetal				
							8 T.P.I. No.70444	10 T.P.I. No.70445	14 T.P.I. No.70446	18 T.P.I. No.70493	24 T.P.I. No.70447
Galvanized Iron pipe	Under 3/4"				○	○				○	○
	1"-2 1/2"			○	○				○	○	
	3"-4"			◎	◎				◎	◎	
	5"-6"			◎					◎		
	8"-10"		◎	●				◎	●		
Conduit Pipe	Thin wall					○					○
	Thick wall			○	○				○	○	
Angles, Steels & Rods (Thickness, mm)	Under 3.6				○	○				○	○
	3.7-6			◎	◎				◎	◎	
	6.1-7.9	○	◎	●			○	◎	●		
	8-9.9	○	●	●			○	●	●		
	Over 10	●					●				
Stainless Steel Pipe (Thickness, mm)	Under 2.0										○
	2.1-3.9								○	◎	◎
	4.0-6.4							◎	◎	◎	
	6.5-13.5						◎	●	●		
	13.6-18.2						●				
PVC Pipe				○	○						
Ductive Cast Iron Pipe for Drain (excluding Mortared Cast Iron Pipe)			○	◎				◎	●		

\*1. In saw blade selection, choose T.P.I. to satisfy the condition that there are two or more teeth in the thickness of a workpiece.

\*2. The above chart is a guideline. Select the saw blade and cutting load according to the workpiece.

# BEAVER 8·8F

## [ Hydraulic Model ]

● : 3~5   ◎ : 2~4   ○ : 1~3

\*Frame falling time is controlled by Hydraulic Cylinder, and cutting time is influenced by temperature.

Ex) In case of the chart shows 3~5, set the knob at "3" in over 20°C, at "4" in 20~10°C, at "5" in under 10°C.

		8 T.P.I. No.70439	10 T.P.I. No.70440	14 T.P.I. No.70441	18 T.P.I. No.70442	24 T.P.I. No.70443	Bimetal				
							8 T.P.I. No.70444	10 T.P.I. No.70445	14 T.P.I. No.70446	18 T.P.I. No.70493	24 T.P.I. No.70447
Galvanized Iron pipe	Under 3/4"				○	○				○	○
	1"-2 1/2"			○	○				○	○	
	3"-4"			◎	◎				◎	◎	
	5"-6"			◎					◎		
	8"-10"		◎	●				◎	●		
Conduit Pipe	Thin wall					○					○
	Thick wall			○	○				○	○	
Angles, Steels & Rods (Thickness, mm)	Under 3.6				○	○				○	○
	3.7-5			○	○				○	○	
	5.1-7	○	◎	◎			○	◎	◎		
	7.1-9.9	○	●	●			○	●	●		
	Over 10	●					●				
Stainless Steel Pipe (Thickness, mm)	Under 2.0										○
	2.1-3.9								○	◎	
	4.0-6.4							◎	◎	◎	
	6.5-13.5						◎	●	●		
	13.6-18.2						●				
PVC Pipe				○	○						
Ductive Cast Iron Pipe for Drain (excluding Mortared Cast Iron Pipe)			○	◎				◎	●		

\*1. In saw blade selection, choose T.P.I. to satisfy the condition that there are two or more teeth in the thickness of a workpiece.

\*2. The above chart is a guideline. Select the saw blade and cutting load according to the workpiece.

## 3-2) Falling time of the Frame by Speed Adjust Knob Setting

Reference : Falling time of the Frame (at 25 °C)

Speed Adjust scale	1	2	3	4
Falling time	1m40s~ 2m40s	50s~ 1m25s	30~40s	18~28s

\*Frame falling time is controlled by Hydraulic Cylinder, and cutting time is influenced by temperature.

# BEAVER 8·8F

---

## 2. INSTALLATION

### 1) Carrying the Machine

#### WARNING



- When lifting the machine, bend your knees to avoid a load on your waist.
- The machine with chip is slippery. Do not drop the machine on your feet while lifting it.

### 2) Transport

#### CAUTION



- Set Speed Adjust Knob in “5” during transportation, otherwise it may cause a malfunction.
- Fix the machine in position so that it is stable and does not move about while being transported.

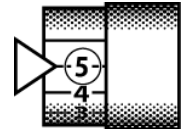

### 3) Installation

#### DANGER



- Always ground the machine to avoid electric shock or resultant death.
- Do not touch the plug with wet hands.
- Do not expose the machine to rain and water and do not use it in damp or wet locations. Humidity will deteriorate motor insulation or lead to electric shock.



- Immediately replace Power Plug, Power Cord or extension cord, if damaged.
- An extension cord used should be a three-core cable having an earth wire. Use a thick and durable cord for outdoor use.

#### WARNING



- Never install an earth wire to the gas pipe. If attempted, explosion may take place.
- Do not use the machine in the presence of flammable liquids or gases such as gasoline and thinner. Otherwise, ignition or explosion may take place.

- (1) Put the machine in a place free from moisture.
- (2) Put the machine on a flat surface without play or on a flat work bench.
- (3) Secure a sufficient space around the machine. A wide space is necessary particularly when working long and heavy pipe.
- (4) It is mandatory to use the Pipe Support for long and heavy pipe. Avoid excessive force applied to the machine which causes it to tilt.
- (5) Make sure that the power source is equipped with a ground fault circuit breaker to avoid electric shock.
- (6) Use an earth clip when a power receptacle without a base for grounding is used. (\*1)
- (7) When an extension cord is used, use the one conforming to the applicable regulations. (\*2)

## \*1 Confirmation of Earth (Grounding) and Earth Leakage Circuit Breaker

Before starting use of the machine, make sure that the power supply to which this machine will be connected is fitted with an earth leakage circuit breaker for prevention of electric shock (earth leakage circuit breaker) which conforms to the occupational safety and health law, electrical equipment technical standard, etc.

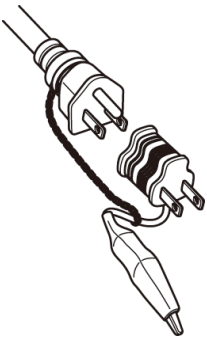

Always ground this machine. It is recommended to ground the machine for your own safety if it is used with a power supply which is fitted with a current-operated earth leakage circuit breaker having the rated sensitivity current of 15 milliamperes (mA) max. and the operating time of 0.1 seconds max. When the receptacle used does not have a ground slot, the earth clip and earth (ground) wire, confirm that they are without fault.

When you have a tester or an insulation resistance meter, check for continuity between the earth clip and the machine's metal frame. Grounding work (for example, burying the earth pole (earth plate, earth bar) in the ground and connecting the earth (ground) wire) must be done by a qualified electrician.

## \*2 Extension Cord

When an extension cord is required for use with a distant power supply, it should be thick enough to carry a current and as possible to ensure that the product is used with the maximum efficiency without a failure.

The extension cord used must be a three-core cable having one earth (grounding) core.

## 4) Proper working environment

The working area should be put in order following the clauses in "OPERATING INSTRUCTIONS".

### Noise Prevention Control

Noise is controlled as set forth in relevant regulations. The machine must be operated at less than the control value to avoid discomfort to the neighborhood. Sound barriers may be required under some circumstances.

## 3. OPERATION

### 1) Replacement the Saw Blade

#### ⚠ CAUTION



- Be sure to unplug the unit from power supply before changing the blade.
- When a new saw blade is used, test cuts are required as it is liable to cut obliquely.  
[Spring model]  
Cut a workpiece once or twice at the cutting load position “ L”.  
[Hydraulic model]  
First few workpieces should be cut at about a half the ordinary cutting speed.
- Install the saw blade after completely wiping oil and dirt off.
- Use the genuine ASADA Band Saw Blade.
- Band Saw Blade is sharp, so don't hand with bare hands.

(1) Remove the Back-Plate Stopper to take off the Back Plate. <Fig.1>

(2) Turn the Tension Handle to “RELEASE” direction. <Fig.2>

(3) Slide the Blade Guide F forward. <Fig.3>

(4) Fix new saw blade into the Blade Guide carefully on both sides.

(5) Place saw blade on Pulley and hold saw blade in Blade Guide.

\*For easy setting, catch saw blade with the Saw Blade Receiving Washer.

(6) Turn the Tension Handle to “TENSION” direction.

\*Before turning on switch make sure saw blade is on Pulley.

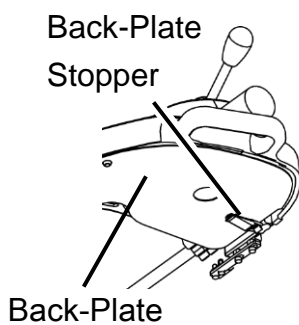

<Fig.1>

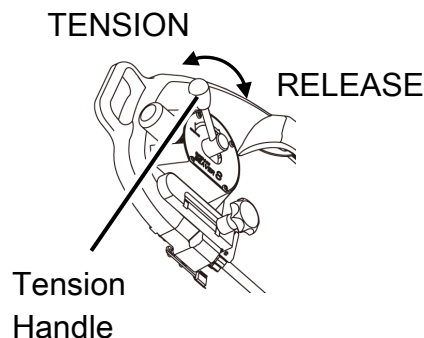

<Fig.2>

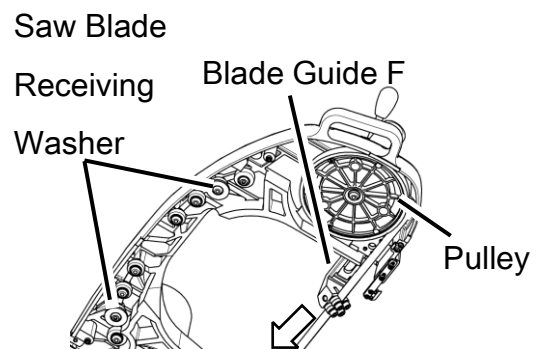

<Fig.3>



## 2) Adjustment of Blade Guide F

**CAUTION**



-Adjustment of the blade guide F will affect the cutting precision and life of the Saw blade.

### Blade Guide F

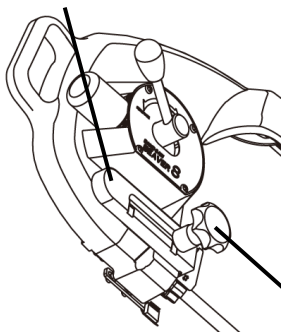

Guide F  
adjustment Knob

- (1) Loosen the Guide F adjustment Knob.
- (2) Set Blade Guide F as close as possible to the workpiece.
- (3) Tighten the Guide F adjustment Knob.

<Fig.4>

## 3) Clamp the material

### 3-1) Chain Vise Type

#### Chain Pin

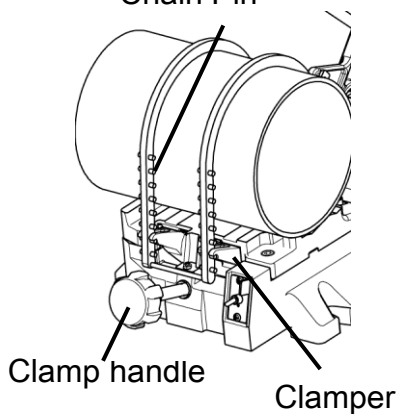

Place the material to be cut so that it will be contact the V-Groove of the vise, grip the chain Handle and pull the Chain over the material. Next, clamp the Chain Pin with the Clasper and then turn the Clamp Handle to clamp tight the material to be cut. Since the Clamp Handle is a Crank-Type extra tightening is possible.

<Fig.5>

# BEAVER 8·8F

## 3-2) Flat Vise Type

- (1) Loosen the hexagon head bolt two places.
- (2) Set the Flat Vise-R to the cutting angle on the scale and tighten the Hex Bolt in the Flat Vise-R. [ Fig.9 ]
- (3) The Flat Vise-F is of quick clamping type. Move the Flat Vise-F toward the work and turn the clamp handwheel to tighten the workpiece quickly.

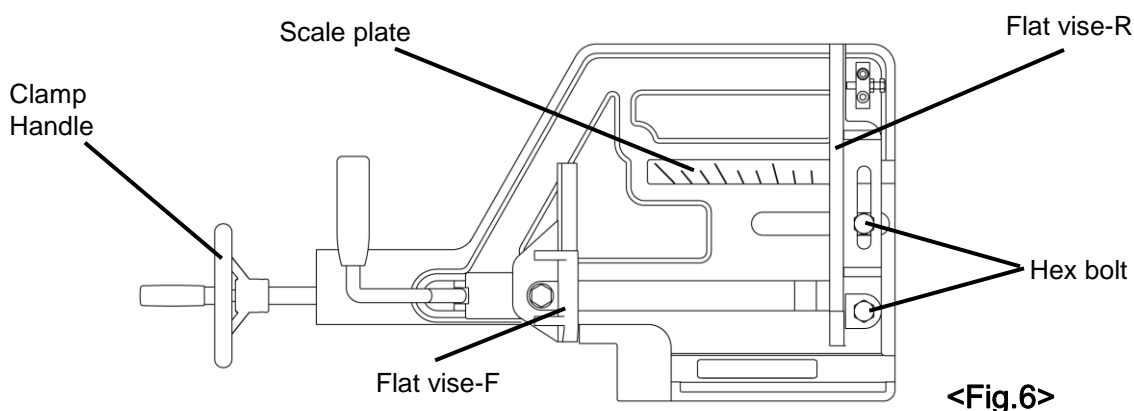

## 4) Adjustment of cutting speed

### CAUTION



-Choose the T.P.I Blade, considering also shape of the materials.

Refer to the Instruction manual p11-12 Saw Blade and Cutting Load Selecting Chart.

-Operate the cutting speed which matches the workpiece.

If you use wrong T.P.I Blade or wrong cutting speed, blade won't work well and it will be broken.

### 4-1) Spring model

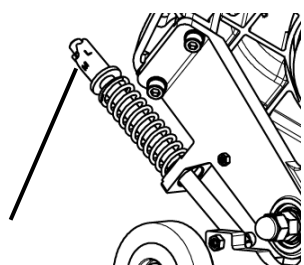

Change Cap

<Fig.7>

- (1) With the Frame raised up, adjust the weight setting to the value indicated on cutting speed chart on the machine or the Instruction manual p11 for the material to be cut.  
For this weight adjustment, press down the Change Cap and set it in the groove of required setting.

## 4-2) Hydraulic Model

### CAUTION



-Do not tighten the Speed Adjust Knob too much hard.  
Otherwise, it may cause a malfunction.

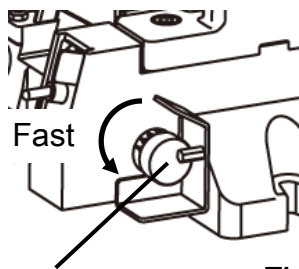

Speed Adjust Knob <Fig.8>

When the Speed Adjust Knob is turned in the direction of an arrow, cutting speed becomes fast.

<b>Cutting speed scale</b>						
Slow	←1	2	3	4	5→	Fast

## 4-3) Adjustment of material position

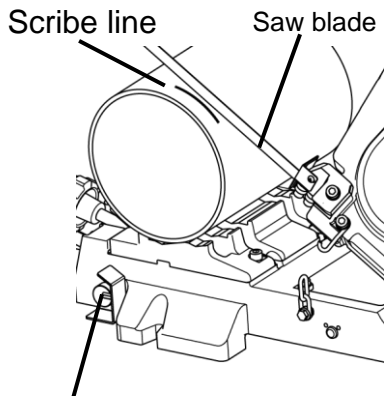

Speed Adjust Knob <Fig.9>

- (1) When bringing a saw blade close to the material, tighten the Speed Adjust Knob and fix the frame.
- (2) Adjust the scribe line of the material to the position of the saw blade and fix the material.

# BEAVER 8·8F

## 5) Cutting



- When plug into the power source, make sure to switch off.
- Do not bring your hand and face close to moving part and Saw Blade.
- Do not wear gloves while operating the unit.

### 5-1) Spring model

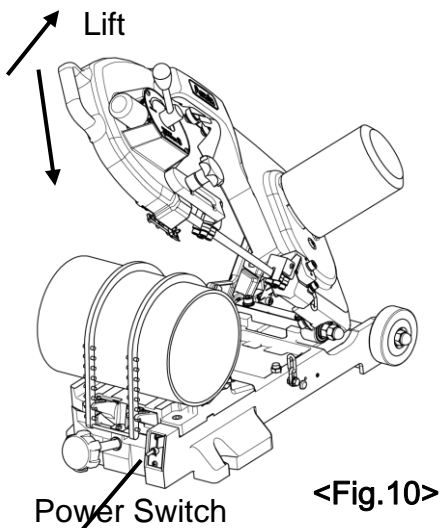

- (1) Lift the Frame to turn the stopper and lower the Blade slowly. Be careful not to allow the Saw Blade to hit the workpieces.
- (2) Blades stops automatically when cut is completed.

### 5-2) Hydraulic Model

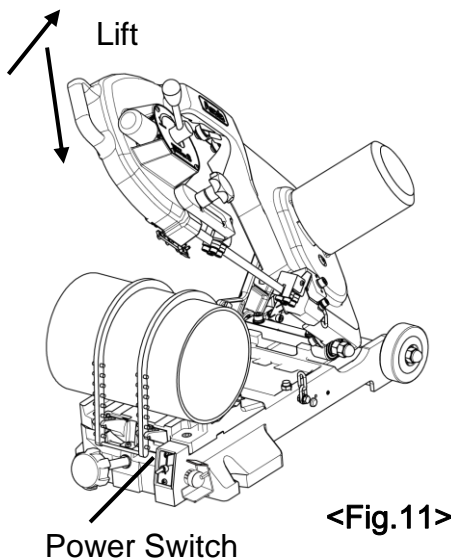

- (1) Turn the Speed adjust knob to "5"
- (2) Lift the Frame to turn the stopper and lower the Blade slowly. Be careful not to allow the Saw Blade to hit the workpieces.
- (3) Turn power switch on and set the Speed adjust knob to proper speed for the workpieces.
- (4) Blades stops automatically when cut is completed.

## 6) Removing the Workpiece 6-1) Chain Vise Type

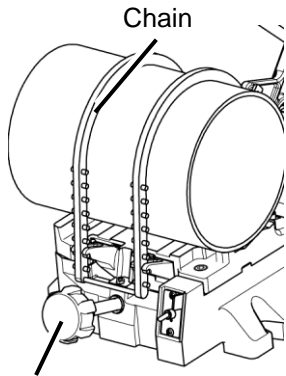

Clamp handle <Fig.12>

After cutting ends, removing the workpiece.

\*Loosen the Clamp Handle and unclasp chain.

Next, remove the workpiece on the unit.

## 6-2) Flat Vise Type

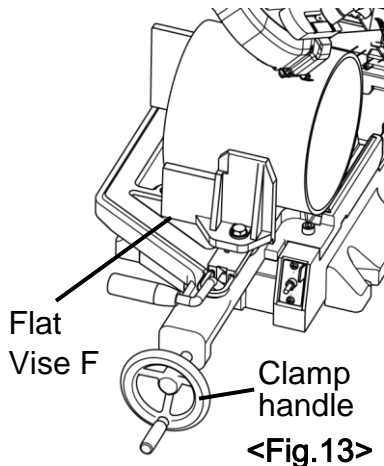

After cutting ends, removing the workpiece.

\*The quickly loosened can be done by separating Flat Vise F from workpiece

After clamp handle is loosened.

### CAUTION



**-Immediately after cutting, fragment are hot. Do not touch them directly with hands.**

Wait for a while or hold the pipe with a cloth. Otherwise you may get burned.

## 4. MAINTENANCE & INSPECTION

### 1) Replacement of Parts

#### 1-1) Replacement the Pulley Rubber

When the Pulley-Rubber wears down, the Saw Blade may come off or slip. Change can be done easily by removing the Pulley, but it can be replaced while still in the machine. If you change it, change Pulley-Rubber meanwhile both front and rear.

**CAUTION**



**-Before replacing the pulley rubber, always disconnect the power cord.**

The machine may start suddenly, leading to injury.

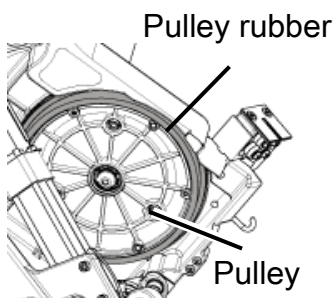

- (1)Detach saw blade referring to page 12 “Replacement the Saw Blade”
- (2)To remove the pulley rubber, pull out its outer periphery by hand.
- (3)Extend a new pulley in the circumferential direction and fit it into the highs and lows of the pulley in sequence. <Fig.14>
- (4)After fitting, hand-turn the pulley and make sure that the rubber fits in the highs and lows completely.

\*Always wipe oil, if any, off the pulley rubber.

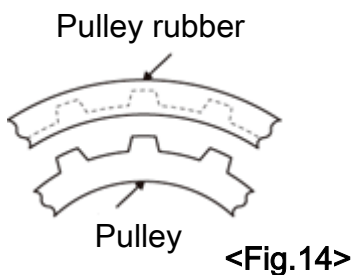

## 2) Correction Procedure for Oblique Cutting (Flat Vise Type)

### ⚠ WARNING



**-Before correction for oblique cutting, always disconnect the power cord.**  
The machine may start suddenly, leading to injury.

(1) Loosen the Bolt and Lock Nut of Flat Vise-R and turn the adjustment bolt to adjust the angle of the Flat Vise R [ Fig.15 ]

When the blade guide head F side longer: Turn the adjustment bolt clockwise.

When the blade guide head R side longer: Turn the adjustment bolt counterclockwise.

\*One turn of the adjustment bolt allows adjustment of about 1mm.

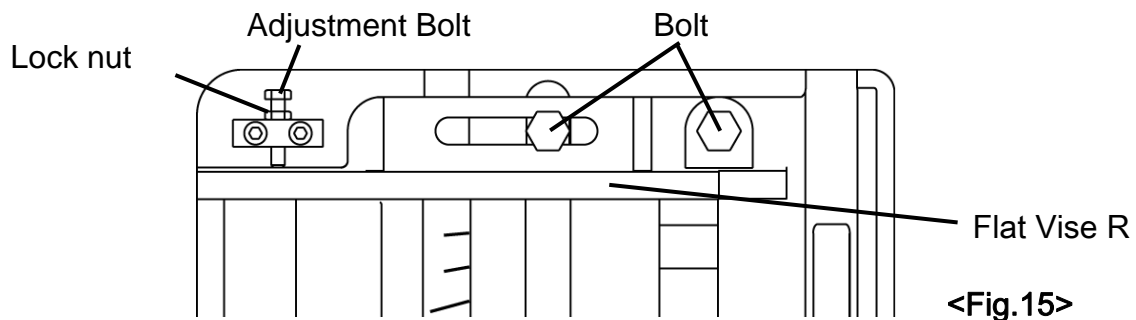

## 3) Daily Inspection and Maintenance

### ⚠ CAUTION



**-Do not wet the motor with water.**

\*Immediately replace Power Plug, Power Cord and extension cord, if damage.

\*Check the saw blade for chipping or damage. Replace if chipping is found. (For the saw blade replacing procedure, refer to page 15 "Replacement the Saw Blade".)

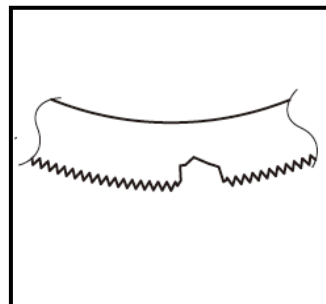

# BEAVER 8·8F

---

\*Check the blade stopper ball bearings and back stopper ball bearings. If they are not set correctly, cutting accuracy will decline. When the ball bearings are worn, replace them as soon as possible. (Replace all the bearings on both sides.)

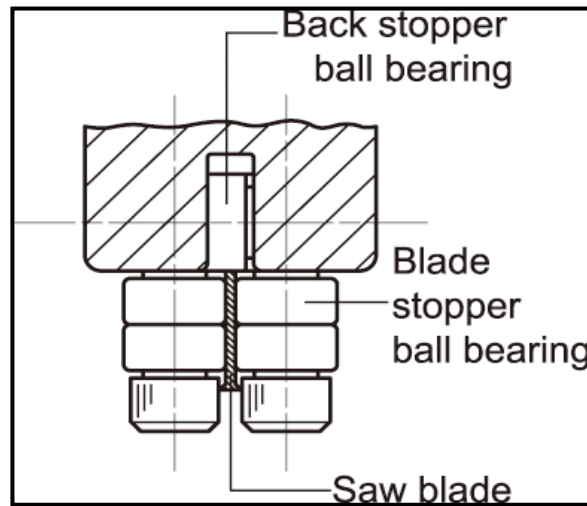

\*Check for loose fitting screws of parts. If used loosened, danger can result. Retighten them.

\*Completely wipe off dirt and chips from the machine.

\*Check cylinder, hose and speed adjust knob if there are oil leak. If find oil leak, stop using this machine and ask our company to do those repairs.

\*Coat the machine with rust preventive grease when the machine is not used for a long period of time.



## 5. BEFORE ASKING FOR REPAIRS

Trouble	Possible Cause	Solution
Oblique cutting	Test cuts not enough.	When a new saw blade is used, it is liable to cut obliquely and test cuts must be made. If cut obliquely occurred, this saw blade will probably make cut obliquely even so doing adjustment of up-down oblique cutting. So, change to a new saw blade and do test cuts surely before using.
	Cutting speed is not suitably.	Adjust cutting speed according to the workpiece.
	Saw blade setting improper.	Securely set the saw blade into the blade guide bearings.
	Saw blade used caused oblique cut before, or saw blade is worn.	Replace the saw blade.
	T.P.I. not matching workpiece.	Select the saw blade having T.P.I. which matches the workpiece.
	Blade guides or bearings worn.	Replace the bearings. (Replace on both sides at the same time.)
	Workpiece moved during cutting.	Tighten a rectangular workpiece so that it is as low as possible.
	Workpiece tightening improper.	Tighten the workpiece in contact with the V groove or flat surface.
	Tension handle setting improper.	Securely set the tension handle in its tightening direction.
	Slide blade guides not near enough.	Set the slide blade guide nearer to the workpiece.
	Saw blade is not genuine.	Use the genuine saw blade.
Cutting time long.	Cutting speed is not suitably.	Adjust cutting speed according to the workpiece.
	T.P.I. not matching workpiece.	Select the saw blade having T.P.I. which matches the workpiece.
	Saw blade worn.	Replace the saw blade.
Saw blade chipping.	Cutting load heavy.	Set the cutting load adjustment according to the workpiece.
	Workpiece moved during cutting.	Tighten the workpiece in contact with the V groove or flat surface.
	Saw blade hit the workpiece.	Put the saw blade onto the workpiece gently and release your hand from the handle.
	T.P.I. not adequate.	Use the saw blade having T.P.I. adequate for the workpiece.

# BEAVER 8·8F

Trouble	Possible Cause	Solution
Vibration while sawing.	Tension handle not set in tightening direction.	Set the tension handle in the tightening position.
	Installation of Back-Plate is bad.	Move mounting position of Back-Plate Stopper.
	Adjustment of blade guide F.	If blade guide F is really close to a workpiece, it may cause vibration. So, separate blade guide F and workpiece 20-30mm.
	Wobble of the body.	If fixed aspect is not flat and the body have wobble, these things may cause vibration. In this case, Put the machine on a flat surface without play or on a flat work bench.
Saw blade coming off	T.P.I. not matching workpiece.	Select the saw blade having T.P.I. which matches the workpiece.
	Saw blade setting fault.	Re-set the saw blade until it makes contact with the back stopper
	Saw blade or Pulley rubber or Workpiece or Blade guide and bearing stained with oil.	Wipe oil off the Saw blade or Pulley rubber or Workpiece or Blade guide and bearing and re-set it.
	The movement of Following Pulley is poor.	Remove foreign matter to run the following pulley smoothly.
	Tension handle tightening fault.	Set the tension handle in position.
	Pulley rubber worn.	Replace the pulley rubber.
Saw blade sinking	Saw blade lower than workpiece at end of cutting	Adjust the stop bolt to raise the saw blade position.
Motor will not run	Overload protector activated.	Press the overload protector re-set button.
	Voltage dropped or long extension cord used. Various machines connected to the same receptacle.	Use an extension cord of large capacity. (Refer to page 14.)
Workpiece cannot be clamped	Clamp bolt worn.	Replace the Clamp bolt.

**6. ELECTRICAL WIRING DIAGRAM**

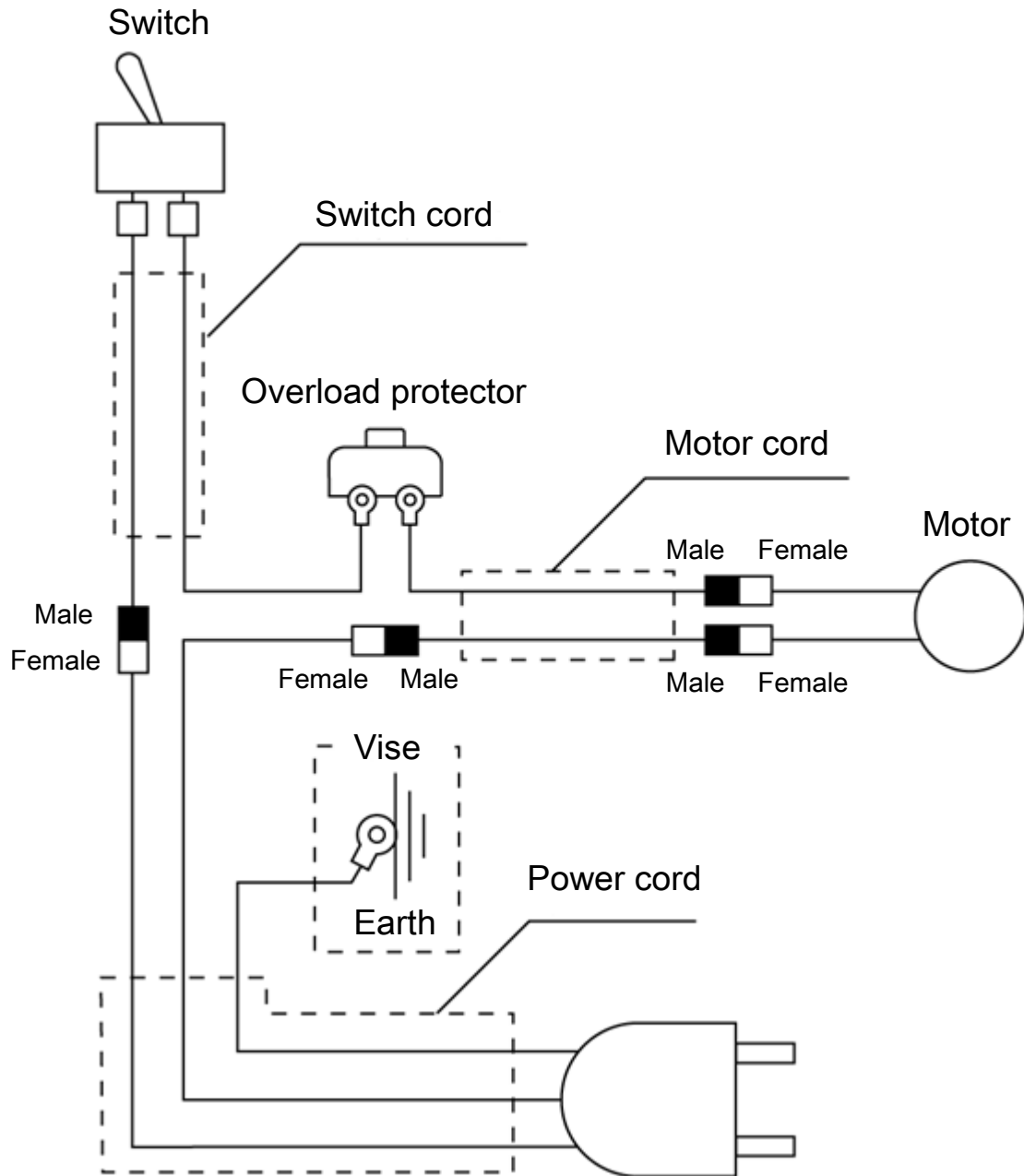

## CUSTOMER NOTE

Please enter the following for future use. This note will be useful in making inquiries and placing purchase orders for part

**SERIAL NO, :**

**DATE OF PURCHASE :**

**SALES REPRESENTATIVE :**

**Asada**  
ASADA CORPORATION

3-60, Kamiida, Nishi-Machi, Kita-Ku, Nagoya, Japan 462-8551

TEL +81-52-914-1062

URL <http://www.asada.co.jp>

FAX +81-52-914-1065

E-mail: [trade@asada.co.jp](mailto:trade@asada.co.jp)